

**TM 11-6665-230-12**

**OPERATOR'S AND ORGANIZATIONAL  
MAINTENANCE MANUAL**

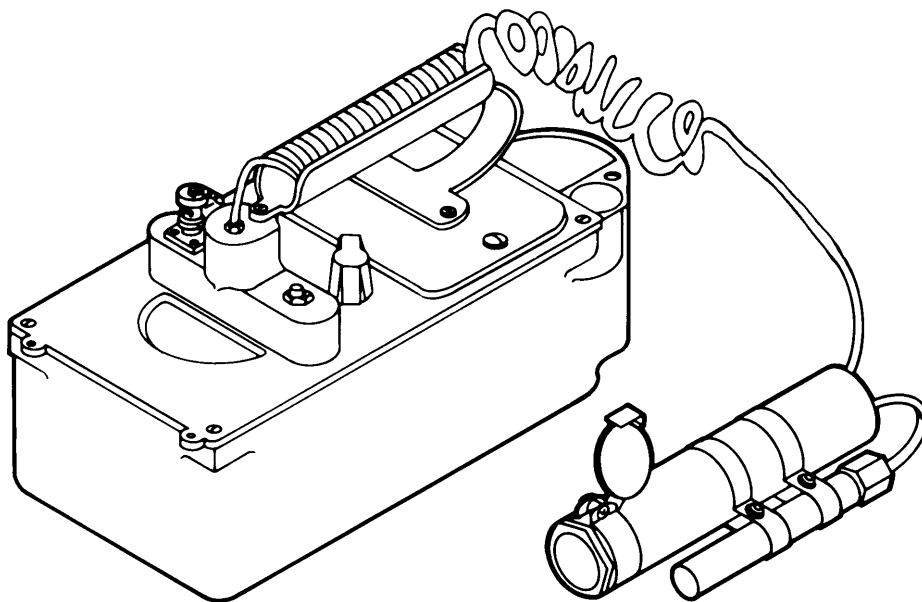

**RADIAC SET  
AN/PDR-27R  
(NSN 6665-00-961-0846)**

**HEADQUARTERS, DEPARTMENT OF THE ARMY**

**3 SEPTEMBER 1984**

**WARNING**

HIGH VOLTAGE  
DEATH ON CONTACT

Be careful when working on this equipment. The high voltage power supply produces 580 volts d.c..



KRYPTON 85

The Radioactive Test Sample MX-7338/PDR-27 contains 5 millicuries of KRYPTON 85. Damage to body tissue can result from mishandling.

Refer to TM 3-6665-264-10 for specific Instructions on control, safe handling, Inspection, storage and disposition of the test sample.



**5**

**SAFETY STEPS TO FOLLOW IF SOMEONE IS THE VICTIM OF ELECTRICAL SHOCK**

**1**

**DO NOT TRY TO PULL OR GRAB THE INDIVIDUAL**

**2**

**IF POSSIBLE, TURN OFF THE ELECTRICAL POWER**

**3**

**IF YOU CANNOT TURN OFF THE ELECTRICAL POWER, PULL, PUSH, OR LIFT THE PERSON TO SAFETY USING A WOODEN POLE OR A ROPE OR SOME OTHER INSULATING MATERIAL**

**4**

**SEND FOR HELP AS SOON AS POSSIBLE**

**5**

**AFTER THE INJURED PERSON IS FREE OF CONTACT WITH THE SOURCE OF ELECTRICAL SHOCK, MOVE THE PERSON A SHORT DISTANCE AWAY AND IMMEDIATELY START ARTIFICIAL RESUSCITATION**

**OPERATOR'S AND ORGANIZATIONAL MAINTENANCE MANUAL  
RADIAC SET AN/PDR-27R  
(NSN 6665-00-961-0846)**

**REPORTING ERRORS AND RECOMMENDING IMPROVEMENTS**

You can help improve this manual. If you find any mistakes or if you know of a way to improve the procedures, please let us know. Mail your letter, DA Form 2028 (Recommended Changes to Publications and Blank Forms), or DA Form 2028-2 located in the back of this manual direct to: Commander, US Army Communications-Electronics Command and Fort Monmouth, ATTN: DRSEL-ME-MP, Fort Monmouth, New Jersey 07703. In either case, a reply will be furnished direct to you.

		Page
	HOW TO USE THIS MANUAL . . . . .	i
CHAPTER	1 INTRODUCTION . . . . .	1-1
Section	I General Information . . . . .	1-1
	II Equipment Description and Data.. . . .	1-2
CHAPTER	2 OPERATING INSTRUCTIONS . . . . .	2-1
Section	I Description and Use of Operator's Controls . . . . .	2-14
	II Preventive Maintenance Checks and Services (PMCS) . . . . .	2-1
	III Operation Under Usual Conditions . . . . .	2-16
CHAPTER	3 OPERATOR MAINTENANCE INSTRUCTIONS . . . . .	3-1
	4 ORGANIZATIONAL MAINTENANCE INSTRUCTIONS . . . . .	4-1
APPENDIX	A REFERENCES . . . . .	A-1
	B MAINTENANCE ALLOCATION . . . . .	B-1
	C COMPONENTS OF END ITEM AND BASIC ISSUE ITEMS LIST . . . . .	C-1
	D ADDITIONAL AUTHORIZATION LIST. . . . .	D-1
	E EXPENDABLE SUPPLIES AND MATERIALS LIST . . . . .	E-1
GLOSSARY	. . . . .	GLOSSARY 1
INDEX	. . . . .	INDEX 1

**HOW TO USE THIS MANUAL**

This manual describes the Operator's and Organizational maintenance function only.

Direct Support maintenance is not applicable.

Chapters, sections, paragraphs and tables are listed in numeric sequence.

A summary and definition of all maintenance functions and tool and test equipment requirements are located in Appendix B.

\*This manual supersedes so much of TM 11-6665-230-15 dated 20 June 1967 as pertains to operators and organizational maintenance.

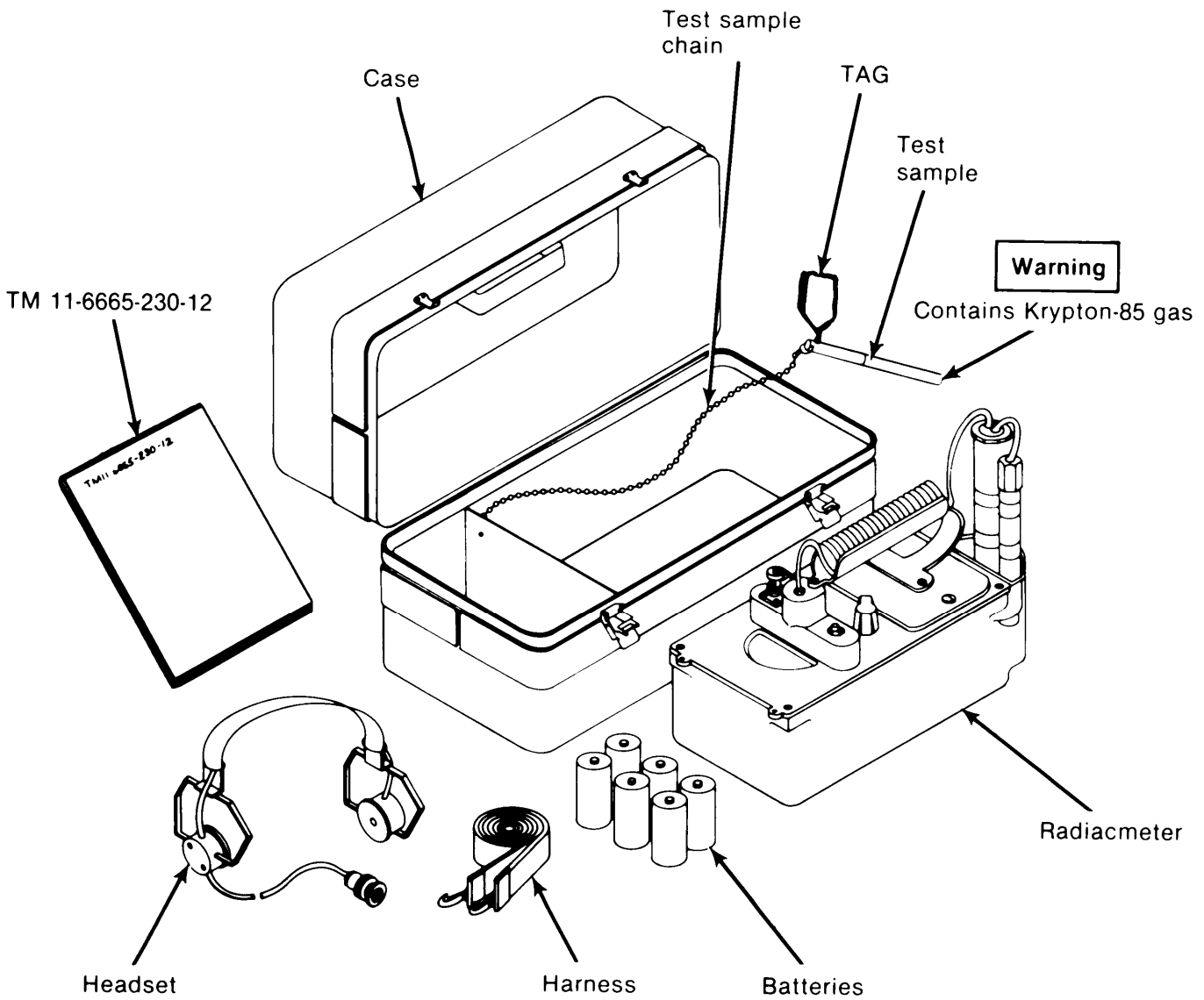

EL6NC001

Figure 1-1. Radiac Set AN/PDR-27R

# CHAPTER 1

## INTRODUCTION

---

### Section I. GENERAL INFORMATION

#### 1-1. SCOPE

a. This manual describes Radiac Set AN/PDR-27R, and contains instructions for installation, operation, and operator and organizational maintenance. It includes operation under usual conditions, cleaning and inspection of the equipment, functioning of the equipment, troubleshooting, and replacement of parts.

b. The Radiac Set AN/PDR-27R detects beta radiation and measures and detects gamma nuclear radiation.

#### 1-2. CONSOLIDATED INDEX OF ARMY PUBLICATIONS AND BLANK FORMS

Refer to the latest issue of DA Pam 310-1 to determine whether there are new editions, changes, or additional publications pertaining to the equipment.

#### 1-3. MAINTENANCE FORMS, RECORDS, AND REPORTS

a. *Reports of Maintenance and Unsatisfactory Equipment.* Department of the Army forms and procedures used for equipment maintenance will be those prescribed by DA Pam 738-750 as contained in Maintenance Management Update.

b. *Report of Packaging and Handling Deficiencies.* Fill out and forward SF 364 (Report of Discrepancy (ROD)) as prescribed in AR 735-11-2/DLAR 4140.55/NAVMATINST 4355.73A/AFR 400-54/MCO 4430.3F.

c. *Discrepancy in Shipment Report (DISREP) (SF 361).* Fill out and forward Discrepancy in Shipment Report (DISREP) (SF 361) as prescribed in AR 55-38/NAVSUPINST 4610.33C/AFR 75-18/MCO P4610.19D/DLAR 4500.15.

#### 1-4. DESTRUCTION OF ARMY ELECTRONICS MATERIEL

Destruction of Army electronics materiel to prevent enemy use shall be in accordance with TM 750-244-2.

#### 1-5. ADMINISTRATIVE STORAGE

Administrative storage of equipment issued to and used by Army activities will have preventive maintenance performed in accordance with the PMCS charts before storing. When removing the equipment from administrative storage the PMCS should be performed to assure operational readiness. Disassembly and repacking of equipment for shipment or limited storage are covered in paragraph 4-2.

#### 1-6. REPORTING EQUIPMENT IMPROVEMENT RECOMMENDATIONS (EIR)

If your Radiac Set AN/PDR-27R needs improvement, let us know. Send us an EIR. You, the user, are the only one who can tell us what you don't like about your equipment. Let us know why you don't like the design. Put it on an SF 368 (Quality Deficiency Report). Mail it to Commander, US Army Communications-Electronics Command and Fort Monmouth, ATTN: DRSEL-ME-MP, New Jersey 07703. We'll send you a reply.

#### 1-7. HAND RECEIPT (-HR) MANUALS

This manual has a companion document with a TM number followed by "-HR" (which stands for Hand Receipt). The TM 11-6665-230-12-HR consists of preprinted hand receipts (DA Form 2062) that list end item related equipment (i.e., COEI, BII and AAL) you must account for. As an aid to property accountability, additional -HR manuals may be requisitioned from the Commander, Baltimore AG Publications Center, 2800 Eastern Blvd., Baltimore, MD 21220 in accordance with the procedures in chapter 3, AR 310-2 and DA Pam 310-10-2.

1-8. NOMENCLATURE CROSS REFERENCE LIST

COMMON NAME	OFFICIAL NOMENCLATURE
Radiac Set	Radiac Set AN/PDR-27R
Radiacmeter	Radiacmeter IM-203/PDR-27R
Harness	Harness, ST-136/PDR-27R
Headset	Headset, Electrical H-43 B/U
Case	Case, Carrying CY-4995/PDR-27R
Test Sample	Radioactive Test Sample MX-7338/PDR-27R
Battery	Battery, Dry BA-30
Probe	Radiac Detector DT-196/PDR-27R

Section II. EQUIPMENT DESCRIPTION AND DATA

1-9. EQUIPMENT PURPOSE, CAPABILITIES AND FEATURES

a. *Purpose.* The AN/PDR-27R is designed to detect beta radiation and measure and detect gamma nuclear radiation.

b. *Capabilities* and *features*

- (1) Portable.
- (2) Watertight.
- (3) Lightweight.
- (4) Battery operated.
- (5) Rugged.
- (6) Detects and measures gamma radiation alone or detects beta nuclear radiation.

1-10. LOCATION AND DESCRIPTION OF MAJOR COMPONENTS In figure 1-2 is a diagram of the individual components of Radiac Set AN/PDR-27R. A description of each component follows:

a. **Radiacmeter IM-203/PDR-27R (fig. 1-2) (1).** The radiacmeter includes a housing made of two aluminum castings with a gasketed seam. The top casting or panel supports all of the electronic circuitry and includes a separate sealed battery compartment. The bottom casting acts as a cover which encloses the electronic circuitry and the battery compartment. The unit is powered by six BA-30 batteries.

1. Mounted on the panel is an indicating meter, a function switch, a meter illumination switch and a headset jack.

2. The indicating meter is mounted behind a sealed glass window for waterproofing. It has five removable scales which are mechanically coupled to the range switch so that the scale corresponding to the switch position is presented.

3. The carrying handle provides space for storing the detector cable when the detector is placed into the mounting well.

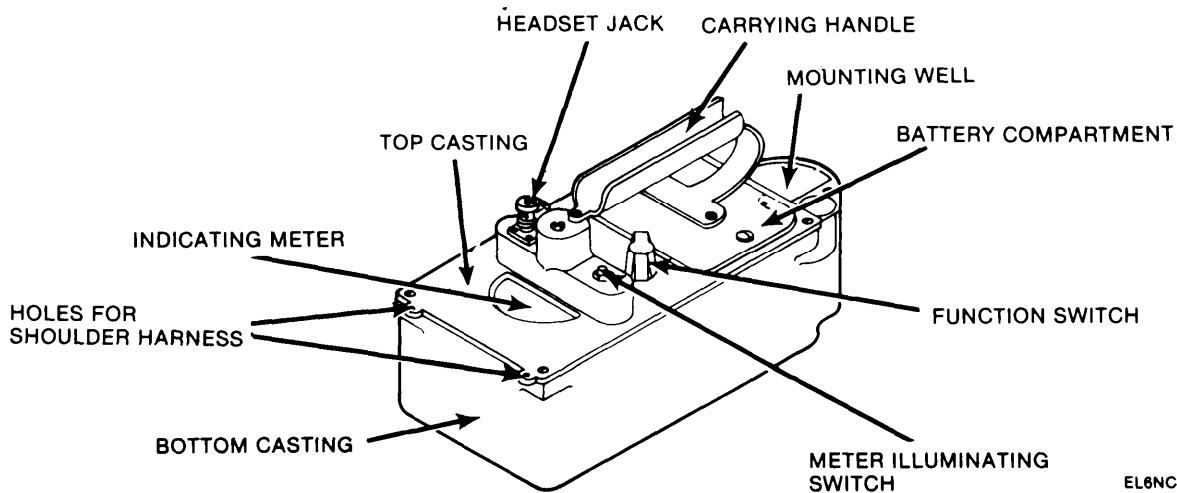

EL6NC002

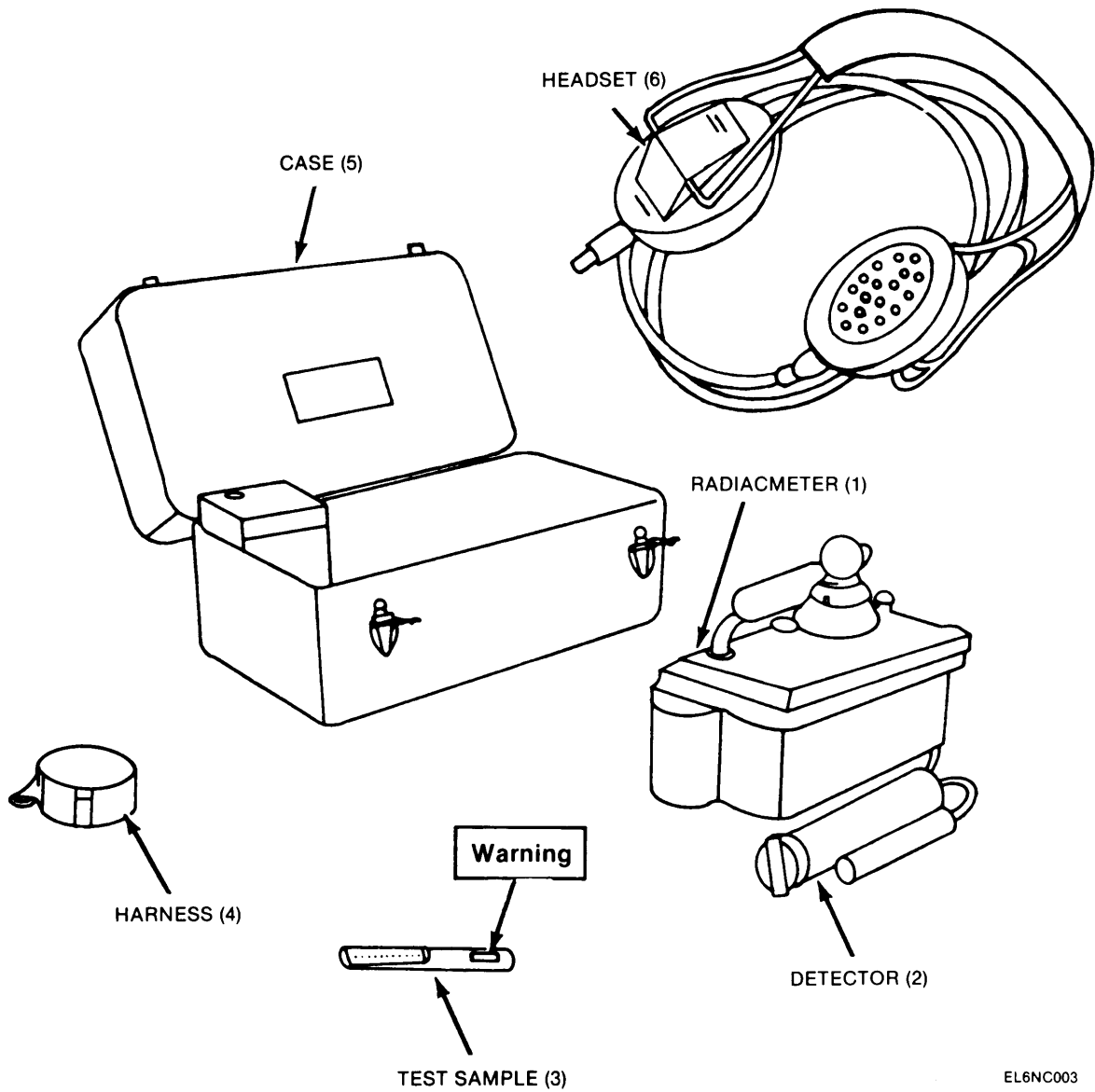

EL6NC003

Figure 1-2. Major Components of Radiac Set AN/PDR-27R



b. Radiac Detector DT-196/PDR27R. (fig. 1-2) (2).

**CAUTION**

The mica window of the probe is 0.0005 inches thick, and it is extremely fragile. Do not touch the window under any circumstances as the Geiger-Mueller (G-M) tube will be damaged. Do not rely upon the guard ring to protect the mica window. The guard ring openings are large enough so that sharp objects may pierce the window.

1. The radiac detector is a probe consisting of MIL-type 5979 and 5980 Geiger-Mueller (G-M) tubes, each enclosed in a separate metal housing. The two housings are clamped together into one unit. A movable metal shield normally covers the mica window of the larger tube. When the shield covers the window, beta radiation is excluded from the tube. The shield can be swung aside when beta-plus gamma radiation readings are desired.

2. Electrical connections for both Geiger-Mueller (G-M) tubes are made at the ends of the metal housings where the shielded cables pass through waterproof packing glands to the tube electrodes. The probe cable is flexible and kink proof and is normally coiled in the space on top of the handle.

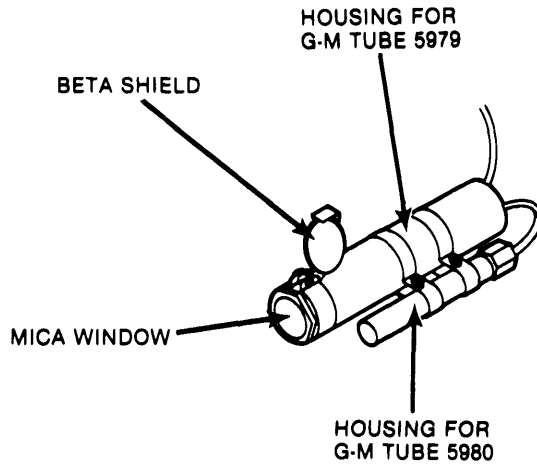

EL6NC004

c. Radioactive Test Sample MX-7338/PDR-27R. (fig. 1-2) (3).



Krypton-85 is a gas which is radioactive, emitting beta and gamma radiation. In this test sample, the shielding permits only the gamma radiation to escape.

Krypton is chemically inert. If the test sample is damaged so that the capsule leaks, remove the sample to a well-ventilated area. If the sample is examined with a Radiac Set AN/PDR-27( ) or another equally sensitive set and is found to be free of radioactivity, the gas has escaped and the sample is harmless. The radioactive test sample consists of an aluminum tube holding a capsule containing 5 millicuries of Krypton-85 gas. The tube is flattened at one end for handling. The Krypton-85, is shielded by the holder and provides a gamma radiation source that permits the operator to check the operating condition of the radiac set.

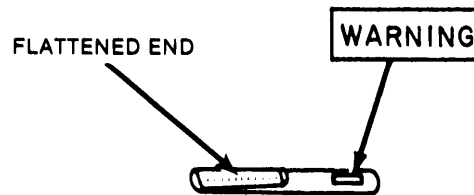

EL6NC005

d. **Harness ST-136/PDR-27R. (fig. 1-2) (4).** The shoulder harness, and adjustable strap made of non-absorbent plastic, is used for carrying the radiacmeter during operation. Clip fasteners at each end of the strap snap into holes in small projections on the radiacmeter panel.

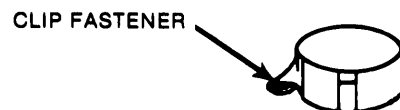

EL6NC006

e. **Case CY-4995/PDR-27R. (fig. 1-2) (5).** The carrying case houses all the other units of the radiac set. It is splash proof and is equipped with a welded-on carrying handle. The case is deep-drawn aluminum and can readily be decontaminated. Compartments to carry a spare set of batteries as well as all the other components are provided in the case. A warning label and nomenclature plates are shown outside the case. (fig. 1-3).

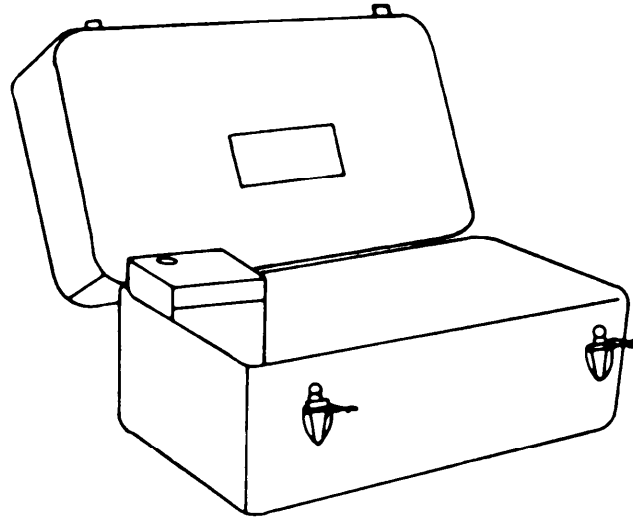

EL6NC007

f. **Headset H-43B/U. (fig. 1-2) (6).** The headset provides the operator with audible indications of radiation intensity when plugged into the jack on the panel. The headset is designed to be worn within or without a battle helmet.



EL6NC008

**1-11. DIFFERENCES IN MODELS** The Radiac Set AN/PDR-27R is similar in appearance to Radiac Sets AN/PDR-27J, AN/PDR-27P and AN/PDR-27Q, and performs the same functions. It differs from these models only in its internal circuitry.

**1-12. EQUIPMENT DATA**

a. Weights and Dimensions.

NOMENCLATURE	HEIGHT	WIDTH	LENGTH	WEIGHT
Radiac Set AN/PDR-27 (Uncrated: without batteries)	9.25"	9.25"	15.75"	14.8 pounds

## b. Performance Data.

1. Type of radiation detection: Detects gamma radiation alone or gamma and beta radiation together.
2. Types of indication: Meter readings (visual) and audible checks.

**NOTE**

For scientific and technical reasons, nuclear radiations are measured in 2 varieties of units, to include the "roentgen" (r), "roentgen equivalent physical" (rep), "radiation absorbed dose" (rad), and "centigray" (cGy). For practical military use, all types of radiation are measured in centigray. This unit of measurement is used interchangeably with, and in lieu of, other units previously mentioned.

3. Sensitivity ranges: Four sensitivity ranges: 0.5, 5, 5.0, and 500 milliroentgens per hour (mR/hr)(5 uGy(mrad)/hr)(50 uGy(mrad)/hr)(500 uGY(mrad)/hr)(5000 uGY(mrad)/hr)
4. Power requirements: Six BA-30, 1.5-volt dry cell batteries.
5. Characteristics: Portable, battery-operated, individually carried and capable of close range detection of weak radiation.

**1-13. SAFETY, CARE AND HANDLING**

The test sample used in this equipment is radioactive. Damage to body tissue can result from mishandling.

- Do not remove the test sample from the chain attaching it to the carrying case.
- Do not handle the test sample by the radioactive end (purple end). Do not prolong exposure to the radiation and handle the test sample un-protected.

**1-14. PRINCIPLES OF OPERATION** The radiac set indicates the presence of radiation by clicks in the headset and by readings shown on the radiacmeter panel meter. The meter reading and the frequency of the clicks are proportional to the radiation intensity.

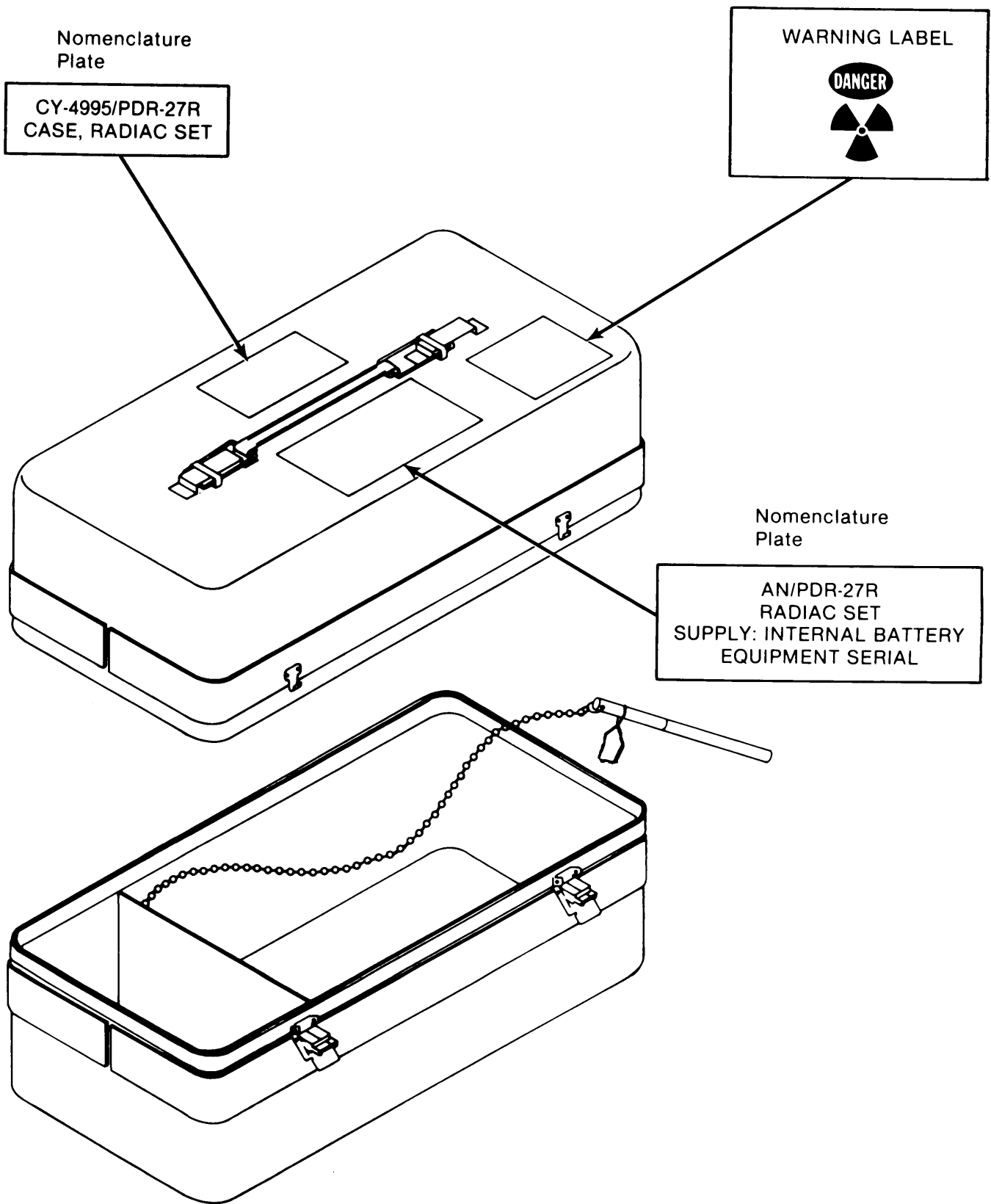

Figure 1-3. Case, CY-4995/PDR-27R

EL6NC009

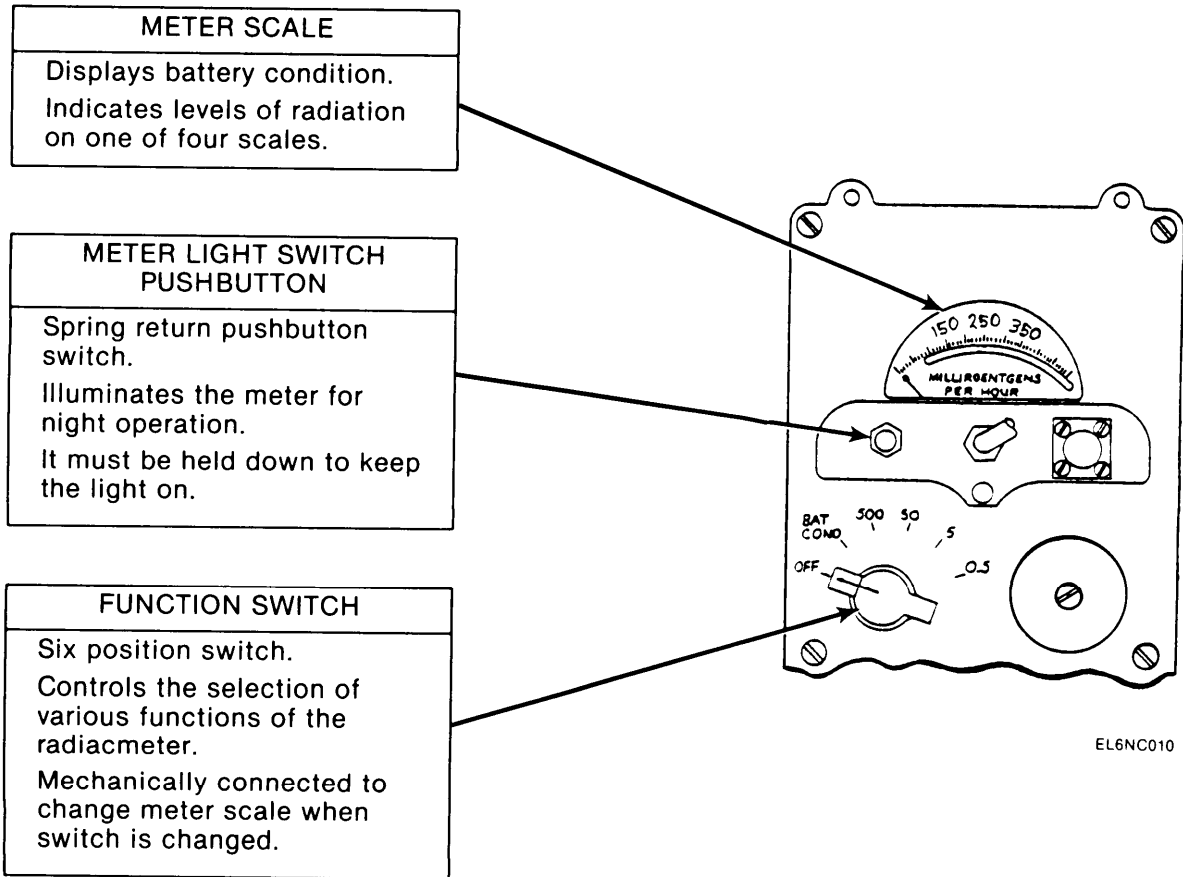

Figure 2-1. Radiacmeter Controls and Indicators

## CHAPTER 2

### OPERATING INSTRUCTIONS

#### SECTION I DESCRIPTION AND USE OF OPERATOR'S CONTROLS AND INDICATORS

**2-1. OPERATOR CONTROLS AND INDICATORS (fig. 2-1)** The six position function switch performs the following functions:

Switch Position	Radiacmeter Function
OFF	No power or removal of power
BAT CON D	Connects battery to meter for battery checks

#### NOTE

The next 4 switch positions connect the batteries to operate the radiacmeter in different ranges of sensitivity.

500	First scale on the meter; used to measure strong radiation levels up to 500 mR/hr. (5000 u Gy (mrad)/hr)
50	Second scale on the meter; used to measure radiation levels up to 50 mR/hr. (500 u Gy (mrad)/hr)
5	Third scale on the meter; used to measure weak radiation levels up to 5 mR/hr. (50 u Gy (mrad)/hr)
0.5	Lowest on the meter; used to measure weak radiation levels up to 0.5 mR/hr. (5 u Gy (mrad)/hr)

#### SECTION II PREVENTIVE MAINTENANCE CHECKS AND SERVICES (PMCS)

##### 2-2. GENERAL

#### NOTE

To be sure that the Radiac Set is always ready for use, you must do PREVENTIVE MAINTENANCE CHECKS AND SERVICES (PMCS).

a. **Before You Operate.** Perform your B PMCS to be sure that the Radiac Set is always ready for use. Always keep in mind the CAUTIONS and WARNINGS that appear in this manual (fig. 2-1).

b. **While You Operate.** Perform your D PMCS. This should help you spot small troubles before they become big problems. Always keep in mind the CAUTIONS and WARNINGS that appear in this manual.

c. **After You Operate.** Perform your A PMCS. This should help you keep the Radiac Set in top shape.

d. **When The Radiac Set Fails To Operate.** Follow the maintenance instructions in Chapter 3. Report any deficiencies using the proper forms in accordance with DA Pam 738-750

##### 2-3. PMCS PROCEDURES (Table 2-1)

a. The PROCEDURES column in your PMCS chart instructs you to "CHECK AND HAVE REPAIRED OR ADJUSTED AS NECESSARY". Carefully follow these instructions and if tools are needed or the chart instructions tell you, get organizational maintenance to do the necessary work.

b. Use the ITEM NO. column in your PMCS table to get the numbers for the TM ITEM NO. column on DA Form 2404 (Equipment Inspection and Maintenance Work sheet) when you fill out the form.

**2-4. ROUTINE CHECKS**

- Routine checks are a collection of checks and observations performed by the operator at all times.
- Cleaning the outside of the Radiac Set, checking for missing or damaged knobs, straps or decals and checking for loose hardware, They are things that you should do anytime you see they must be done.



Table 2-1. Preventive Maintenance Checks and Services (PMCS)

ITEM NO.	INTERVAL			ITEM TO BE INSPECTED	PROCEDURES CHECK AND HAVE REPAIRED OR ADJUSTED AS NECESSARY	EQUIPMENT IS NOT READY/ AVAILABLE IF
	B	D	A			
1	●			Batteries	<p>Remove the radiacmeter and the (12) batteries from the case and install the batteries in the radiacmeter as follows:</p> <p style="text-align: center;"><b>CAUTION</b></p> <p>Before installing the batteries in the battery compartment, turn the function switch to the OFF position. Damage may result if the batteries are improperly installed.</p>  <p style="text-align: center;">EL6NC011</p>	

Table 2-1. Preventive Maintenance Checks and Services (PMCS) (Continued)

ITEM NO.	INTERVAL			ITEM TO BE INSPECTED	PROCEDURES CHECK AND HAVE REPAIRED OR ADJUSTED AS NECESSARY	EQUIPMENT IS NOT READY/ AVAILABLE IF
	B	D	A			
	●				<p>a. Completely loosen the three captive screws, and remove the handle together with the battery compartment cover.</p>  <p style="text-align: right;">EL6NC012</p>	

Table 2-1. Preventive Maintenance Checks and Services (PMCS) (Continued)

ITEM NO.	INTERVAL			ITEM TO BE INSPECTED	PROCEDURES CHECK AND HAVE REPAIRED OR ADJUSTED AS NECESSARY	EQUIPMENT IS NOT READY/ AVAILABLE IF
	B	D	A			
	•				<p>b. Place the batteries into the battery compartment making sure that the flat end of the battery (negative end (-)) connects to the contacts marked negative ① and the positive end of the battery (the end with the tip) connects to the contact marked positive (+) ② in the bottom of the battery compartment.</p>  <p style="text-align: right;">EL6NC013</p>	

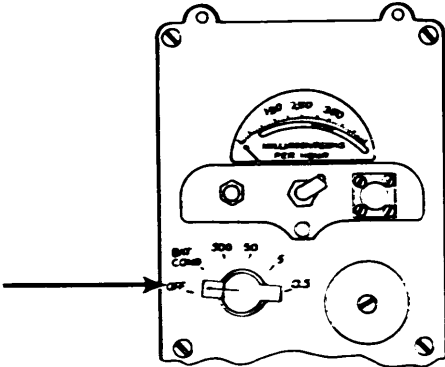
Table 2-1. Preventive Maintenance Checks and Services (PMCS) (Continued)

ITEM NO.	INTERVAL			ITEM TO BE INSPECTED	PROCEDURES CHECK AND HAVE REPAIRED OR ADJUSTED AS NECESSARY	EQUIPMENT IS NOT READY/ AVAILABLE IF
	B	D	A			
	•				<p><b>NOTE</b></p> <p>The illustration below shows the radiacmeter with the batteries in stalled.</p>  <p>EL6NC014</p> <p>c. Replace the handle together with the battery compartment cover, making sure that the rubber bumpers are lined up with the spaces in the center and are seated properly.</p>	

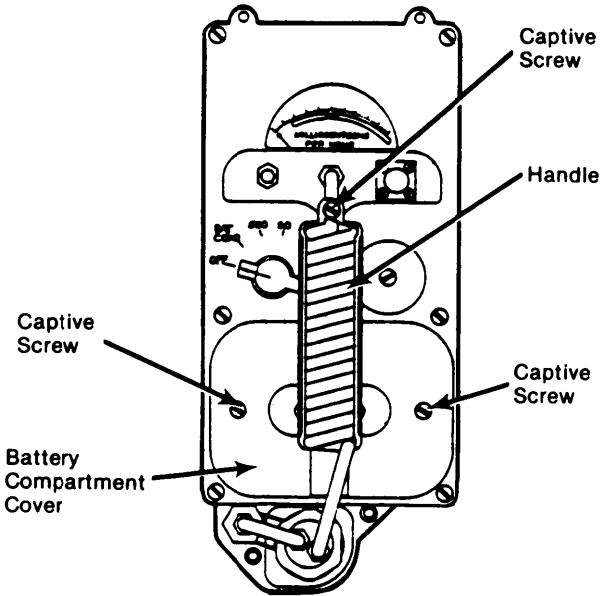
Table 2-1. Preventive Maintenance Checks and Services (PMCS) (Continued)

ITEM NO.	INTERVAL			ITEM TO BE INSPECTED	PROCEDURES CHECK AND HAVE REPAIRED OR ADJUSTED AS NECESSARY	EQUIPMENT IS NOT READY/ AVAILABLE IF
	B	D	A			
	●				<p style="text-align: center;"><b>CAUTION</b></p> <p>Tighten screws securely in order to maintain a watertight battery compartment. Do not tighten too tightly or screw may strip out.</p> <p>d. Tighten the three captive screws that secure the handle and the battery compartment cover to the mounting panel.</p> <div style="text-align: center;">  <p>The diagram shows a cross-section of a battery compartment assembly. It consists of a mounting panel at the top, a battery compartment cover in the middle, and a handle at the bottom. Three captive screws are shown: one at the top center, one at the bottom left, and one at the bottom right. These screws are used to secure the handle and the battery compartment cover to the mounting panel. Labels with arrows point to the Mounting Panel, Captive Screw (top), Battery Compartment Cover, and Captive Screw (bottom left and right).</p> </div> <p style="text-align: right;">EL6NC015</p>	

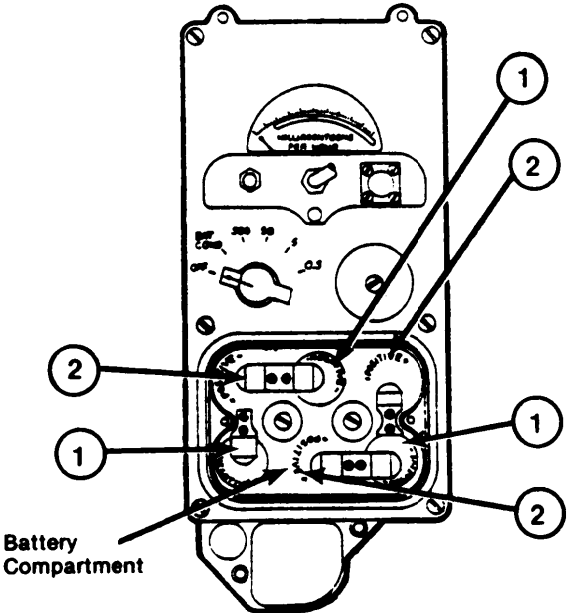
Table 2-1. Preventive Maintenance Checks and Services (PMCS) (Continued)

ITEM NO.	INTERVAL			ITEM TO BE INSPECTED	PROCEDURES CHECK AND HAVE REPAIRED OR ADJUSTED AS NECESSARY	EQUIPMENT IS NOT READY/ AVAILABLE IF
	B	D	A			
	●				<p>e. Place the function switch to BAT CON. The meter needle should move and stop in the area on the meter scale marked BATTERY.</p>  <p>EL6NC016</p>	
					<p>f. Inspect all 12 batteries following the above procedures and store one set (6) of batteries in the storage compartment in the case.</p>	<p>The meter needle does not move into the BATTERY after both sets of batteries have been checked.</p>

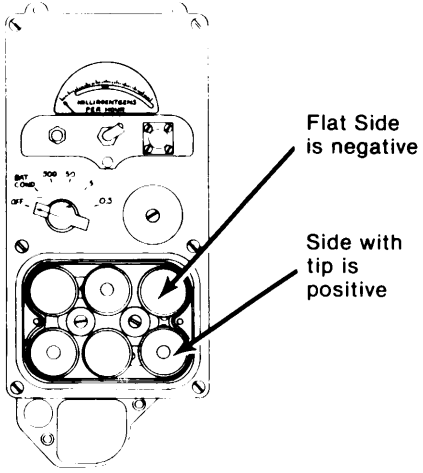
Table 2-1. Preventive Maintenance Checks and Services (PMCS) (Continued)

ITEM NO.	INTERVAL			ITEM TO BE INSPECTED	PROCEDURES CHECK AND HAVE REPAIRED OR ADJUSTED AS NECESSARY	EQUIPMENT IS NOT READY/ AVAILABLE IF
	B	D	A			
2	●			Operating Ranges	<p>Operate the radiacmeter using the test sample and listen for clicks in the headset to check the operation of the radiacmeter as follows:</p> <p>a. Attach the headset to the headset connector on the mounting panel and place the function switch to 500. The meter should read zero.</p>  <p>EL6NC017</p> <p>b. Remove the test sample from the case and the probe from the well.</p> <p>c. Place the active end of the test sample flat against the small cylinder of the probe. The meter needle should indicate up scale. Clicks should be heard in the headset.</p>  <p>EL6NC018</p>	

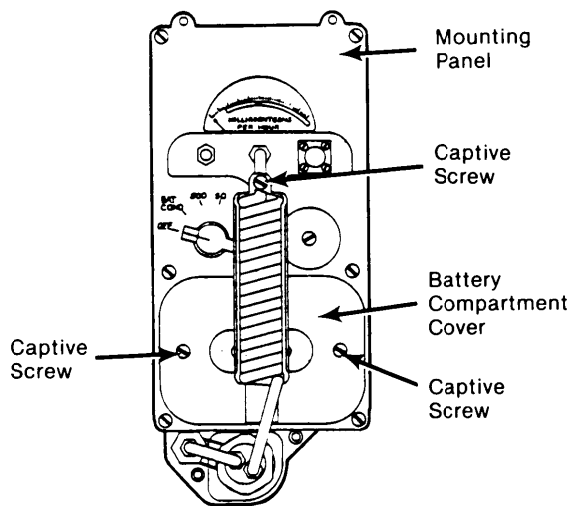
Table 2-1. Preventive Maintenance Checks and Services (PMCS) (Continued)

ITEM NO.	INTERVAL			ITEM TO BE INSPECTED	PROCEDURES CHECK AND HAVE REPAIRED OR ADJUSTED AS NECESSARY	EQUIPMENT IS NOT READY/ AVAILABLE IF
	B	D	A			
	•				<p>d. Turn the function switch to 50. The meter needle should move up scale. Clicks should be heard in the headset.</p>  <p>EL6NC019</p> <p>e. Move the active end of the test sample approximately one inch from the large cylinder of the probe, and turn the function switch to 5. The meter needle should move up scale. Clicks should be heard in the headset.</p>	

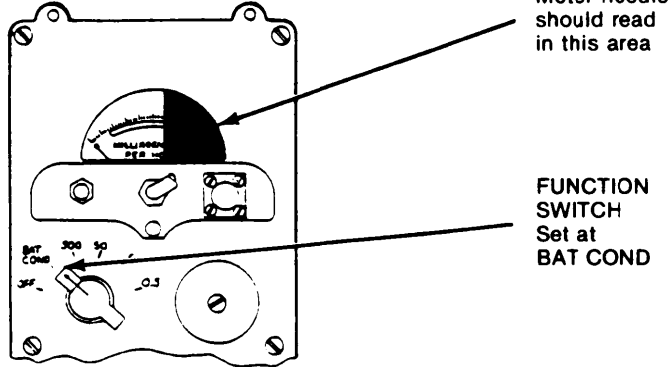

Table 2-1. Preventive Maintenance Checks and Services (PMCS) (continued)

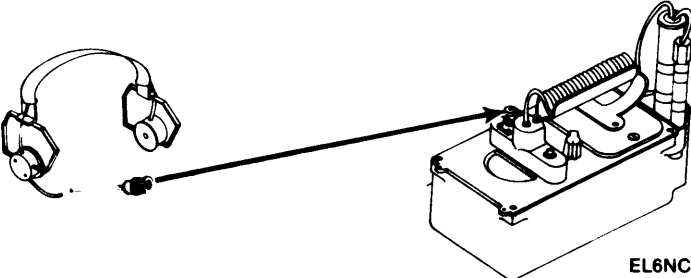
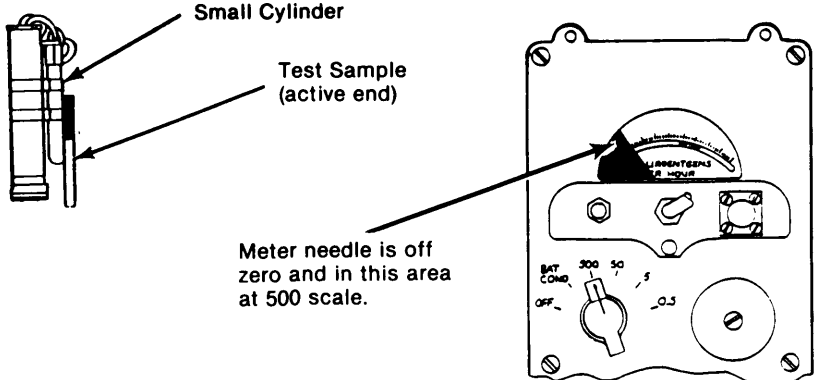
ITEM NO.	INTERVAL			ITEM TO BE INSPECTED	PROCEDURES CHECK AND HAVE REPAIRED OR ADJUSTED AS NECESSARY	EQUIPMENT IS NOT READY/ AVAILABLE IF
	B	D	A			
	•				 <p>Large Cylinder</p> <p>Test sample (active end) 1"</p> <p>Meter needle should be in this area</p> <p>Function switch at 5 scale</p> <p>EL6NC020</p>	

Table 2-1. Preventive Maintenance Checks and Services (PMCS) (continued)

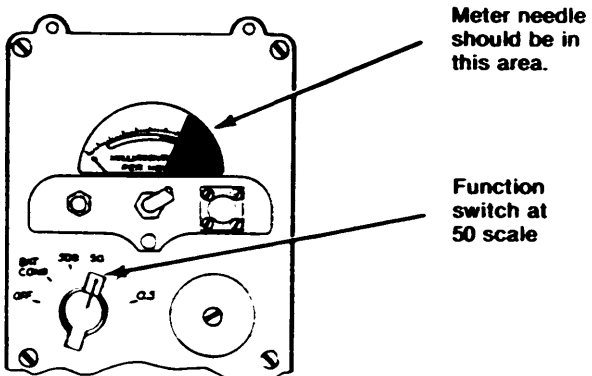
2-12

ITEM NO.	INTERVAL			ITEM TO BE INSPECTED	PROCEDURES CHECK AND HAVE REPAIRED OR ADJUSTED AS NECESSARY	EQUIPMENT IS NOT READY/ AVAILABLE IF
	B	D	A			
	●				<p>f. Move the active end of the test sample approximately 6 inches from the large cylinder of the probe. Turn the function switch to 0.5. The meter needle should move up scale. Clicks should be heard in the headset.</p> <p>Large Cylinder</p> <p>Test sample (active end) 6"</p> <p>Meter needle should be in this area</p> <p>Function switch set at 0.5 scale</p> <p>EL6NC021</p>	No clicks are heard in the headset or if no readings are present on the meter at any scale level.

TM 11-6665-230-12

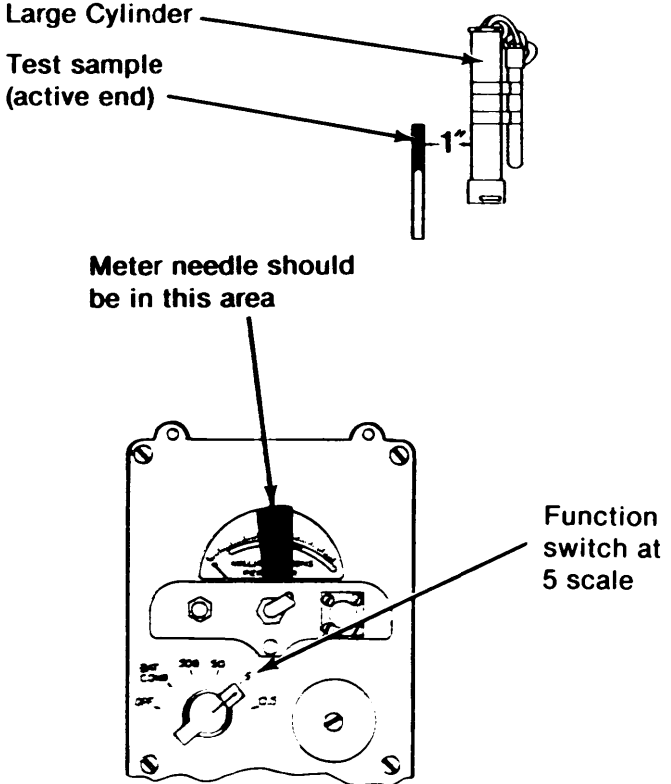
Table 2-1. Preventive Maintenance Checks and Services (PMCS) (continued)

ITEM NO.	INTERVAL			ITEM TO BE INSPECTED	PROCEDURES CHECK AND HAVE REPAIRED OR ADJUSTED AS NECESSARY	EQUIPMENT IS NOT READY/ AVAILABLE IF
	B	D	A			
3	●			Background Radiation (A radiation source)	<p>a. Turn function switch to 0.5. Connect headset and listen for clicks. Watch meter for irregular jumps at low end of scale when clicks are heard.</p> <p>b. Turn function switch to 5. Meter jumps will be greatly reduced but clicks in headset will continue. If meter reading jumps and clicks are heard at random intervals, the two low range positions are in operation.</p> <p>c. Turn the function switch to 50. Listen carefully for clicks. There will be no movement on the meter scale.</p>	Background radiation cannot be heard on headset or seen on meter.

Table 2-1. Preventive Maintenance Checks and Services (PMCS) (continued)

ITEM NO.	INTERVAL			ITEM TO BE INSPECTED	PROCEDURES CHECK AND HAVE REPAIRED OR ADJUSTED AS NECESSARY	EQUIPMENT IS NOT READY/ AVAILABLE IF
	B	D	A			
4	•	•		Meter Light	<p>Check the meter light for operational readiness as follows:</p> <p style="text-align: center;"><b>NOTE</b></p> <p style="text-align: center;">The meter light is used to illuminate the meter in dimly lit areas.</p> <p>a. Turn the function switch to BAT COND.</p> <p>b. Shade the meter from light and press the light switch.</p> <div style="text-align: center;">  <p>Meter light can be seen by viewing the meter from this angle</p> <p>Meter Light Switch, (Pushbutton)</p> <p>EL6NC022</p> </div> <p>c. Light should be seen around the meter scale.</p>	

Table 2-1. Preventive Maintenance Checks and Services (PMCS) (continued)

ITEM NO.	INTERVAL			ITEM TO BE INSPECTED	PROCEDURES CHECK AND HAVE REPAIRED OR ADJUSTED AS NECESSARY	EQUIPMENT IS NOT READY/ AVAILABLE IF
	B	D	A			
5			●	Shutdown	<p>To place the Radiac Set in shutdown or stand-by status:</p> <ul style="list-style-type: none"> <li>a. Turn the function switch to OFF.</li> <li>b. Replace the probe in the well.</li> <li>c. Remove the headset and the harness, and stow both items in the case.</li> <li>d. Remove the batteries and place them in the storage compartment in the case.</li> <li>e. Place the radiacmeter in the case.</li> </ul>	

## SECTION III OPERATION UNDER USUAL CONDITIONS

### 2-5. OPERATING INSTRUCTIONS.

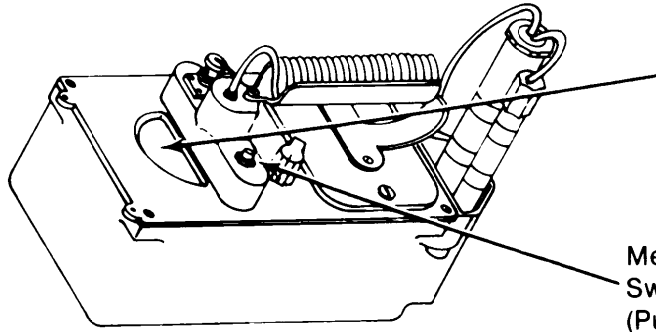
a. Preparation for use.

1. Remove the radiacmeter ① from the case.
2. Install and check the batteries ②. (PMCWS, Table 2-1)
3. Remove the headset ③ from the case and connect it to the headset connector.
4. Remove the harness ④ from the case and install it on the radiacmeter panel.

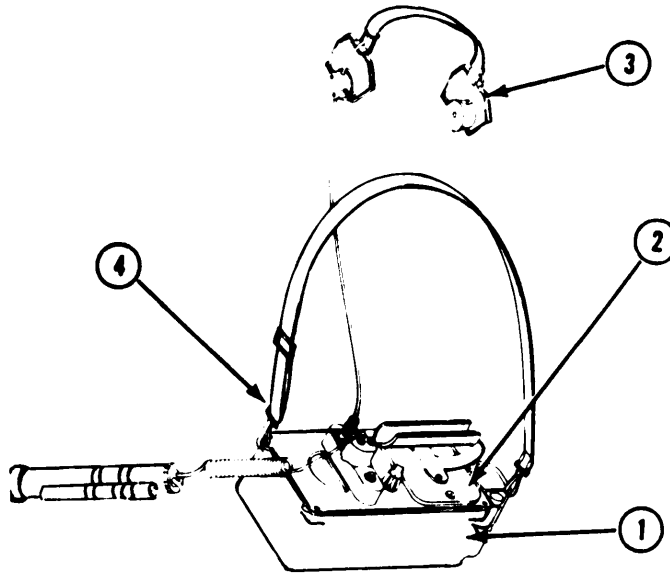

EL6NC023

- b. Operating Procedures. For gamma detection the beta shield on the probe is closed.

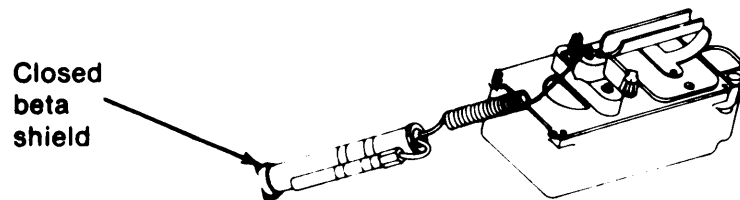

EL6NC024

#### NOTE

It is preferred that the headset be used during all operations.

#### NOTE

If the radiacmeter is used in a dimly lit area, the meter can be illuminated by the meter light

1. Turn the function switch to 0.5.

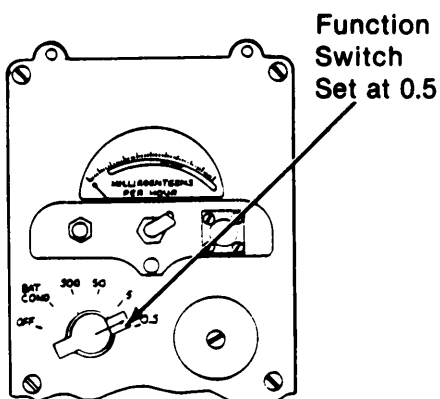

EL6NC025

2. Listen for clicks in the headset and/or observe the meter indications while approaching the suspected radioactive area or object.

**NOTE**

When the needle on the meter is at the upper end (shaded area) of the scale, set the function switch to

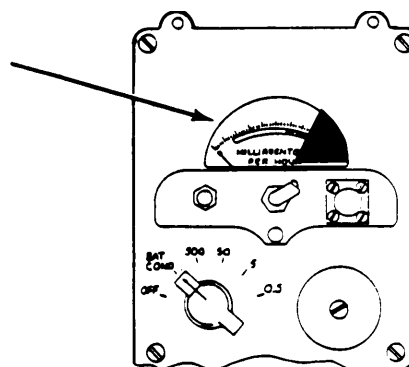

EL6NC026

3. When using the upper ranges (500, 50, or 5) and the needle is at or less than 5 divisions, switch to the next lower (more sensitive) range.
4. To aid in the detection and measurement of radiation of an object that is difficult to reach, set the function switch at 0.5 or 5. Remove the probe from its well and pass the probe over the suspected object. Slowly move the probe back and forth over the object. The closer to the object the more accurate the meter indication will be.

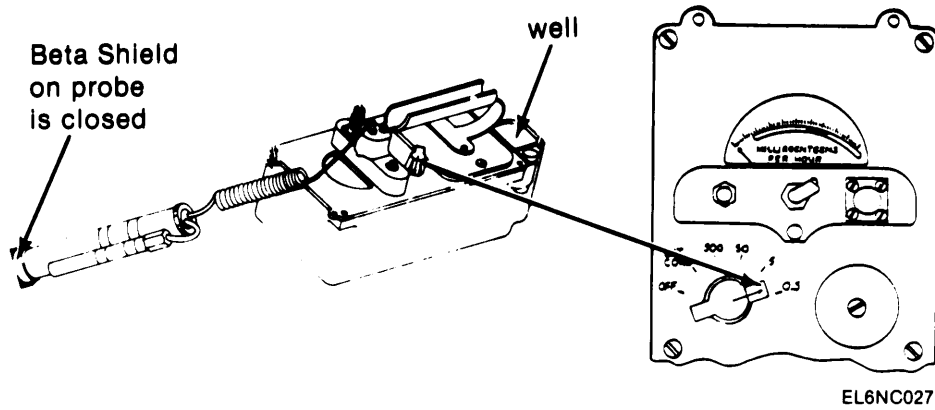

**NOTE**

Radiation intensity decreases rapidly with distance.

c. Detection of beta and gamma radiation.

**CAUTION**

When opening beta shield, make sure not to touch window material underneath beta shield. Window material is very thin and will break if touched.

1. To check the combined beta and gamma radiation of an object, turn the function switch to 5 or 0.5.

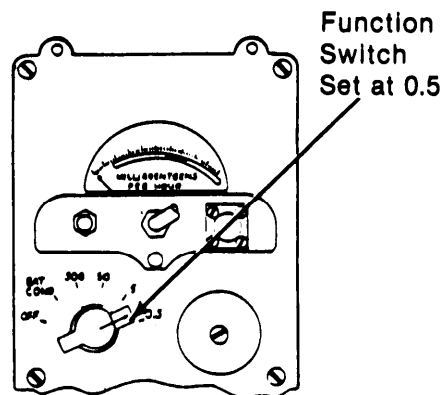
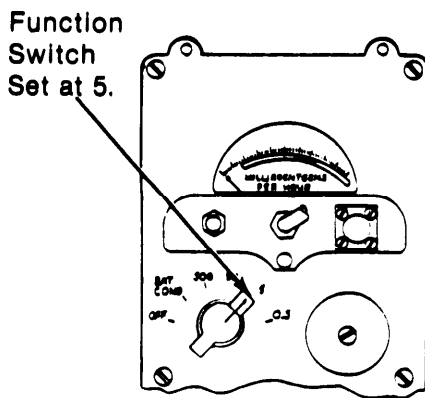

2. Remove the probe from the well, and open the beta shield on the end of the large cylinder of the probe.

3. Point the exposed end of the probe toward the suspected area or object and move it slowly until a readable indication is obtained.



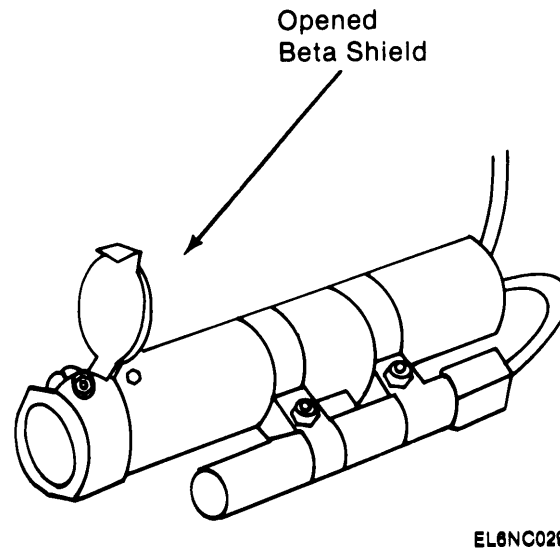

### CAUTION

If the radiacmeter has been used for more than 20 hours, check the condition of batteries by turning the function switch to BAT COND. If the needle moves below mid scale, then replace the batteries with the spare batteries.

d. Stopping the equipment

1. When removal of the radiacmeter from operation is desired, turn the function switch to OFF.
2. Replace the probe in the well.
3. Remove the headset and the harness, and stow both items in the case.
4. Remove the batteries and replace them in the battery storage compartment.
5. Place the radiacmeter in the case.

### NOTE

If one of the major components of the radiacmeter is replaced, the radiacmeter will probably be out of calibration. However, even though the radiacmeter may be inaccurate with respect to absolute intensity, it will still be usable to indicate relative intensity within any one scale position.

This means that it is possible to recognize in which of two locations the intensity is higher, even though the actual intensities are in error. If readings are taken in the two locations on the same scale positions, the reading correctly represents the higher intensity.

## CHAPTER 3. OPERATOR MAINTENANCE INSTRUCTIONS

**3-1. LUBRICATION** There is no lubrication required for the Radiac Set.

### 3-2. TROUBLESHOOTING PROCEDURES

- The troubleshooting Table 3-1 lists the common malfunctions which you may find during the operation or maintenance of the Radiac Set. You must perform the tests, inspections and corrective actions, step by step, as they are listed.
- This manual cannot list all malfunctions that may occur, nor all tests or inspections and corrective actions. If a malfunction is not listed or is not corrected by performing listed corrective actions, notify your supervisor and evacuate to higher maintenance for repair.

### 3-3. OPERATOR MAINTENANCE PROCEDURES

- a. Cleaning. Clean the exposed surfaces of the radiacmeter and the carrying case with a soft damp cloth.
- b. Repairs. The operator is not authorized to make any repairs (other than battery replacement) of the Radiac Set.
- c. Parts Replacement. To replace the batteries refer to Chapter 2, Operating Instructions.

**Table 3-1. Troubleshooting**

---

**MALFUNCTION**

**TEST OR INSPECTION**

**CORRECTIVE ACTION**

---

**RADIAC SET AN/PDR-27R**

1. Needle on the meter is to the left of the center scale when function switch is set at BAT COND.

Open the battery compartment and insure that all the batteries are installed correctly.

Reverse any batteries placed backwards. If all of the batteries are installed correctly, then replace with a new set.

2. Needle on meter moves to the left of zero when the function switch is set at BAT COND.

Set the function switch to off. Open the battery compartment and check that the batteries are installed properly.

Reverse the batteries installed in the battery compartment.

3. No clicks are heard in the headset and no indication is present on any meter scale when the active end of the test sample is approximately six inches from the large cylinder of the probe.

Remove and examine the battery compartment cover for proper installation and condition of the batteries.

Evacuate to a higher level of maintenance.

## CHAPTER 4

# ORGANIZATIONAL MAINTENANCE INSTRUCTIONS

### 4-1. TOOLS, REPAIR PARTS AND SPECIAL TOOLS

- a. For authorized common tools and equipment, refer to the Modified Table of Organization and Equipment (MTOE) applicable to your unit.
- b. Repair parts are listed and illustrated in the repair parts and special tools lists, TM 11-6665-230-20P.
- c. No special tools are required for the maintenance of Radiac Set AN/PDR-27R.

### 4-2. SERVICE UPON RECEIPT

#### NOTE

Save both cartons and material in which the Radiac Set was shipped for storage and shipment purposes,

- a. Unpacking. The Radiac Set will be shipped In a cardboard carton.
  1. Remove the outer carton. ③
  2. Remove the inner carton. ②
  3. Remove the case containing the equipment. Open the case and remove the radiacmeter and its components. ①

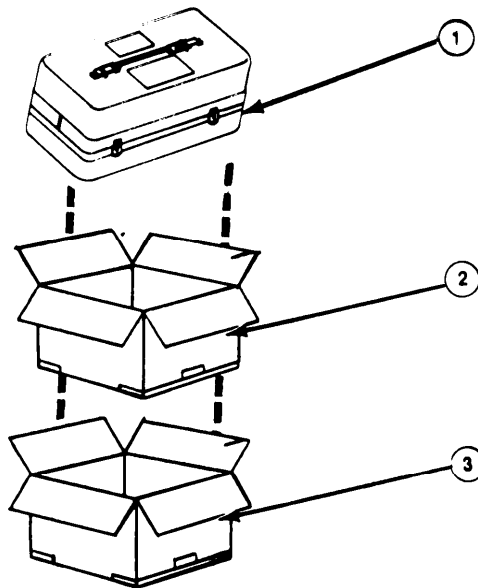

EL6NC030

**b. Checking Unpacked Equipment.**

1. Inspect the equipment for damage incurred during shipment. If the equipment has been damaged, report the damage on SF 364 (Report of Discrepancy (ROD)).

2. Check the equipment against the packing list to see if the shipment is complete. Report all discrepancies in accordance with the instructions of DA Pam 738-750.

**NOTE**

If the packing list is missing, then refer to TM 11-6665-230-12-HR.

3. Check to see whether the equipment has been modified. Refer to DA-PAM 310-1 for the current MWO information on Radiac Set AN/PDR-27R. If the Radiac Set has been modified, then an MWO data plate should appear on the case next to the nomenclature plate.

4. To insure that the equipment will be adequately inspected, serviced and operationally tested before normal everyday use, refer to table 4-1, Service Upon Receipt.

**4-3. PREVENTIVE MAINTENANCE CHECKS AND SERVICES (PMCS).**

a. Use table 4-2 to perform preventive maintenance checks and services to be sure that the Radiac Set is always ready for use.

b. The Item Number column in table 4-2 should be used when making out DA Form 2404, Equipment Inspection and Maintenance Work Sheet. The item numbers in the PMCS table go into the TM Number column on the DA Form 2404.

c. The Procedures column in the table gives instructions to check and have repaired or adjusted as necessary.

d. If the Radiac Set fails to operate, then follow the maintenance instructions in paragraph 3-2, Troubleshooting.

**NOTE**

When performing any PMCS or routine checks, keep in mind the **WARNINGS** and **CAUTIONS** shown in this manual.

**TABLE 4-1. SERVICE UPON RECEIPT**

Item	Action
1. Case	a. Inspect for rust, fungus, paint damage and broken handles and clasps. b. Reject the case if damage prevents it from functioning properly.
2. Harness	a. Inspect the harness for tears. b. Inspect the clips for damage. c. Reject the harness if damaged.
3. Headset	a. Inspect for dirt, fungus and grease. b. Inspect for breaks and cracks in the headset. Inspect for tears in the cables. c. Check the headset connector for looseness. d. Reject the headset if damage will prevent it from functioning properly.
4. Probe	a. Inspect for grease, dirt and fungus. b. Inspect for tears in the cable. c. Reject if the cable is torn.
5. Radiacmeter	a. Inspect for grease, dirt and fungus. b. Check for broken glass and cracks on scale window. c. Check the function switch for looseness or binding. d. Check that the function switch is not cracked or missing. e. Check the captive screws for broken threads or gaskets. f. Check the battery compartment for corrosion or rust and the rubber gasket for damage. g. Operational check - refer to Chapter 2, Preventive Maintenance Checks and Services. h. Reject if the meter glass is broken or if operational check is inconsistent.
6. Test Sample	a. Inspect the test sample for dents, cracks, or splits that may cause leakage. b. If sample is damaged, refer to TM 3-6665-264-10 for disposal instructions.

**WARNING**

Hold the test sample only long enough to make the inspection to avoid unnecessary exposure.

Table 4-2. Organizational Preventive Maintenance Checks and Services (M-Monthly)

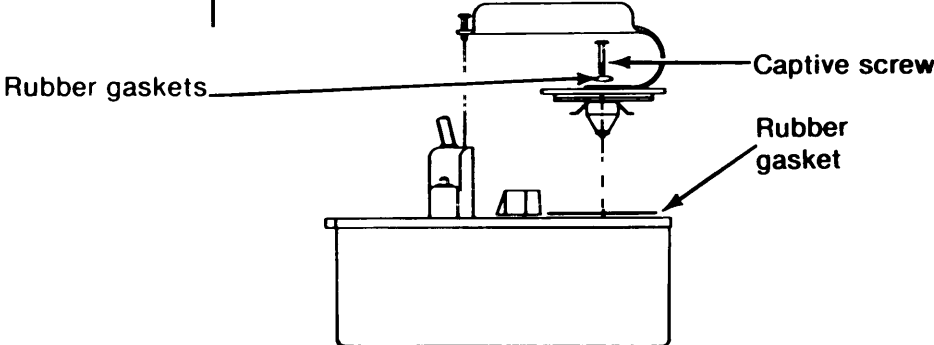
ITEM NO.	INTERVAL M	ITEM TO BE INSPECTED	PROCEDURE
1	●	Painted Surfaces	Check painted surfaces for missing, blistered, or chipped paint. If surface area missing paint is larger than one square inch, touch up painting is required.
2	●	Glass Surfaces	Inspect all glass surfaces for dirt, grease, or fungus. Clean all glass surfaces with a soft cloth. Inspect glass surfaces for cracks or scratches that would impair ability to obtain accurate readings.
3	●	Battery	Inspect the battery compartment for corrosion. Clean if necessary. Check the rubber gaskets for wear, frays, or tears, and replace if necessary.
 <p>The diagram shows a cross-section of a battery compartment. A captive screw is shown passing through a hole in the top cover, secured by a rubber gasket. Another rubber gasket is shown at the bottom of the compartment. Labels with arrows point to 'Rubber gaskets', 'Captive screw', and 'Rubber gasket'.</p>			<p style="text-align: right;">EL6NC031</p>
4	●	Captive Screws	Check for worn threads and broken or worn gaskets. Replace if necessary.
5	●	Function Switch	Check that the knob is not cracked or missing. Check that the knob is not loose or binding. Replace or repair as necessary.

**Table 4-2. Organizational Preventive Maintenance Checks and Services (M-Monthly) (continued)**

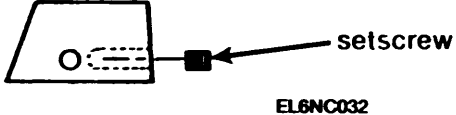
ITEM NO.	INTERVAL M	ITEM TO BE INSPECTED	PROCEDURE
			
6	●	Cables	Check for frays, tears, or cracks on the probe and headset cables.
7	●	Harness	Check for frays or tears. Check for two complete clip fasteners.
8	●	Headset	Check for cracks or breaks.
9	●	Radiac Set Surfaces	Inspect for dirt, grease, and fungus. Clean if necessary.
10	●	Case	Inspect for broken clasps or handles.
11	●	Batteries	Refer to Chapter 2, Preventive Maintenance Checks and Services.
12	●	Radiacmeter	Refer to Chapter 2, Preventive Maintenance Checks and Services.

4-4. TROUBLESHOOTING

**NOTE**

Also refer to Chapter 3, Troubleshooting Table 3-1.

The Troubleshooting Table 4-3 lists the common malfunctions which may be found during the operation or maintenance of the Radiac Set.

This manual cannot list all malfunctions that may occur, nor all tests or inspections and corrective actions. If a malfunction is not listed or is not corrected performing listed corrected actions, notify your Supervisor and evacuate to higher maintenance for repair.

**Table 4-3. Troubleshooting**

---

<b>MALFUNCTION</b>	<b>TEST OR INSPECTION</b>	<b>CORRECTIVE ACTION</b>
--------------------	---------------------------	--------------------------

---

**RADIAC SET AN/PDR-27R**

1. Water seeps into the battery compartment.

Remove the battery compartment cover and check the rubber gasket for damage. Remove the two captive screws on the battery compartment cover and check the gaskets for damage.

Replace the rubber gasket on the mounting panel and/or replace the captive screw gaskets on the battery compartment.

2. The function switch is either loose or binding.

Switch does not turn easily to each setting or does not stop at each setting.

If the function switch is binding, then loosen the setscrew gradually until it turns easily and stops at each setting. If the function switch is loose, then tighten the setscrew so that the switch stops at each setting.

**NOTE**

Tighten the setscrew securely. Do not use excessive force or damage may result.

---



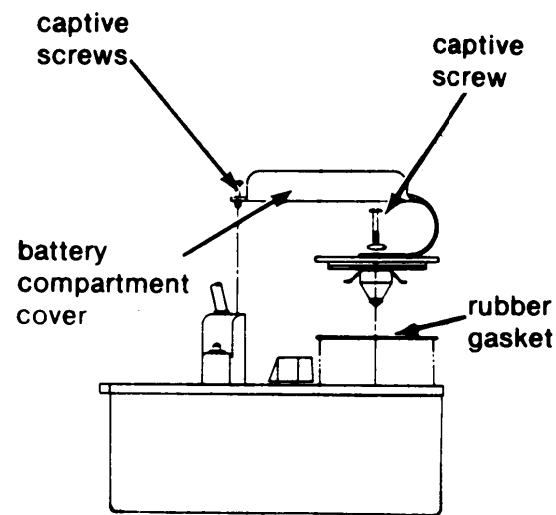

**Table 4-4. Replacement of Parts**

ITEM NO.	LOCATION	TASK	ACTION
1	Battery Compartment	Replace rubber gasket	<p>a. Completely loosen the three captive screws.</p> <p>b. Remove the battery compartment cover.</p> <p>c. Inspect the rubber gasket for damage (tears, frays, excessive wear and looseness). If the rubber gasket is damaged, then remove the gasket.</p> <p>d. Secure a new rubber gasket in place with adhesive (item 2 Appx E). Make sure that the gasket is seated properly in the recessed groove and remove any excess adhesive from around the edges.</p> <p>e. Let the adhesive dry for 5 to 10 minutes, then replace the battery compartment cover.</p> <p>f. Tighten the three captive screws.</p>



EL6NC033

Table 4-4. Replacement of Parts (continued)

ITEM NO.	LOCATION	TASK	ACTION
2	Battery Compartment Cover and Handle	Replace captive screws	<p style="text-align: center;"><b>CAUTION</b></p> <p style="text-align: center;">Tighten the screws securely in order to maintain a watertight battery compartment. Do not tighten too tightly or damage may result to the rubber gaskets.</p> <p>a. Completely loosen the three captive screws.</p> <p>b. Remove the battery compartment cover.</p> <p>c. Remove the damaged captive screw(s) from the handle or the battery compartment cover by rotating the screw counterclockwise.</p> <div style="text-align: center;">  </div> <p>d. Remove the gasket and place it on the new captive screw.</p> <p>e. Replace the screw by turning it clockwise.</p> <div style="text-align: center;">  </div> <p>f. Replace the battery compartment cover, and tighten the three captive screws.</p>

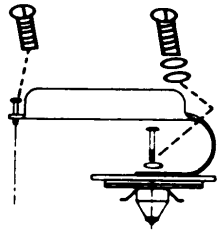

**Table 4-4. Replacement of Parts (continued)**

ITEM NO.	LOCATION	TASK	ACTION
3	Captive screws	Replace gaskets   EL6NC035	<p style="text-align: center;"><b>CAUTION</b></p> <p style="text-align: center;">Tighten the screws securely in order to maintain a watertight battery compartment. Do not tighten too tightly or damage may result to the rubber gaskets.</p> <ol style="list-style-type: none"> <li>a. Refer to steps a, b, and c, item No. 2.</li> <li>b. Remove the damaged gasket and place a new gasket on the captive screw.</li> <li>c. Replace the screw by turning it clockwise.</li> <li>d. Replace the battery compartment cover and tighten the three captive screws.</li> </ol>

Table 4-4. Replacement of Parts (continued)

ITEM NO.	LOCATION	TASK	ACTION
4	Function Switch-knob	Replace Function Switchknob	<p>a. Remove the setscrews from the knob. Pull upwards on knob to remove.</p> <p>b. Remove rubber gasket from under the knob.</p> <p style="text-align: center;"><b><u>CAUTION</u></b></p> <p style="text-align: center;">Do not tighten the screw too tightly or damage may result to the screw.</p> <div style="text-align: center;"><p>EL6NC036</p></div>

**Table 4-4. Replacement of Parts (continued)**

ITEM NO.	LOCATION	TASK	ACTION
5	Headset Connector	Replace Cover, Electrical, Connector	<p>a. Remove the cover, electrical, connector with attaching chain from the headset connector by turning the cover counterclockwise.</p> <p>b. To remove the chain from the mounting panel, turn the screw, counterclockwise.</p> <p>c. Replace the screw with chain attaching the cover by turning it clockwise.</p> <p>d. Replace the cover on the headset connector by turning it clockwise.</p>

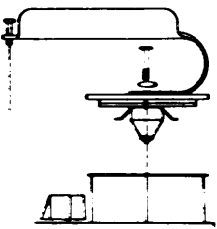
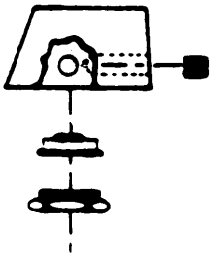
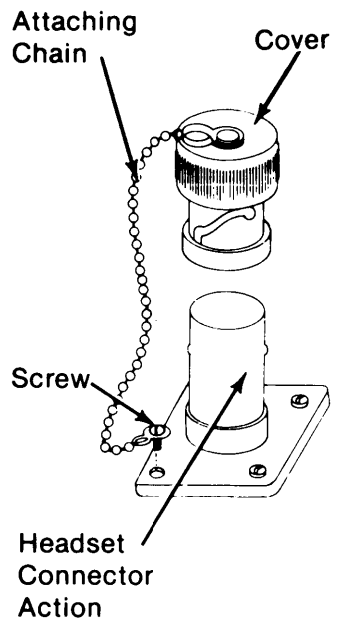

EL6NC037

Table 4-4. Replacement of Parts (continued)

ITEM NO.	LOCATION	TASK	ACTION
6	Calibration Cover	Replace screw sea	<p>a. Remove the damaged screw seal from the aluminum cap by rotating the screw seal counterclockwise.</p> <p style="text-align: center;"><b><u>CAUTION</u></b></p> <p style="text-align: center;">Do not tighten screw or damage may result to rubber gasket</p> <p>b. Replace the screw seal by turning it clockwise.</p>

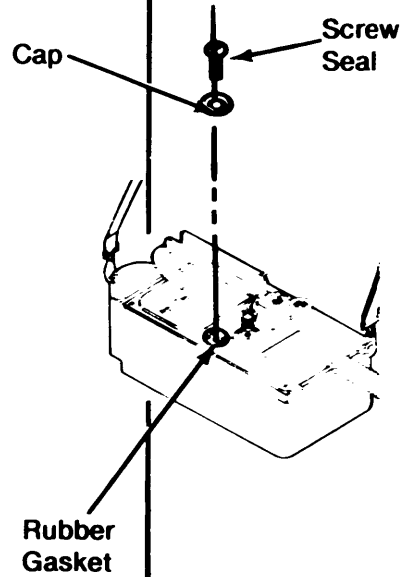

EL6NC038

#### 4-5. REPAIR AND REPLACEMENT OF PARTS

- a. This section gives the necessary procedures to repair and replace damaged parts on Radiac Set AN/PDR-27R (Table 4-4).
- b. The **LOCATION** column gives the area of the damaged item.
- c. The **TASK** column tells what item must be repaired.
- d. The **ACTION** column describes the steps to be followed in order to replace and repair the damaged item.

#### 4-6. ORGANIZATIONAL MAINTENANCE PROCEDURES

- a. **Operational Check.** Refer to Chapter 2, Preventive Maintenance Checks and Services,
- b. **Cleaning.** To clean the Radiac Set surface, wipe with a soft, damp cloth to remove grease, dirt, and fungus.
- c. **Painting.**
  1. Check painted surfaces for missing, blistered or chipping paint. If the surface area missing paint is larger than 1 square inch, touch-up painting is required.
  2. Use paint, item 3, Appendix E.

#### 4-7. PREPARATION FOR STORAGE AND SHIPMENT

- a. Preparation for Storage. The following items must be completed or considered prior to storing the equipment.
- b. Security Procedures.
  1. Security of the stored items is required. The storage area must be secure and prevent items from being stolen.
  2. Items stored must be protected from the weather. Covered storage is required.
  3. Items to be stored must be in good working order. Equipment that is inoperative cannot be stored. Perform the operational check routine on the equipment prior to storage.
  4. When the items are to be put into administrative storage (1 to 45 days) the storage area must be accessible. The equipment in storage must be able to be put into operation within 24 hours.
- c. Type of Storage.
  1. Short term (administrative storage): 1 to 45 days. Administrative storage covers the storage of equipment which can be readied for mission performance within 24 hours. Before placing an item in administrative storage, the next scheduled preventive maintenance check and services should be performed, all known deficiencies corrected, and all current modification work orders applied. The administrative storage site should provide required protection from the elements and allow for visual inspection and exercising when applicable.
  2. Intermediate: 46 to 180 days.
  3. Long term or flyable storage: No time limit.
- d. Preparation for Shipment.
  1. Remove the test sample and place in an adequately shielded and labeled container within a radiologically controlled area.
  2. Place all the components of the Radiac Set in their storage compartments in the case. Place the radiacmeter in the case.
  3. Place the Radiac Set in the Inner carton.
  4. Seal the carton with cloth tape or strapping tape,
  5. Place the Inner carton into the outer carton.
  6. Stuff cardboard strips around the Inner carton to hold it in place
  7. Seal the carton with cloth tape or strapping tape.

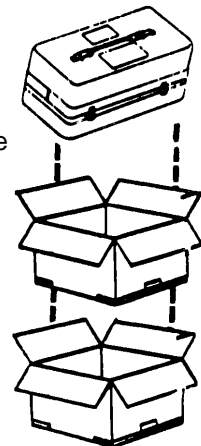

## APPENDIX A

### REFERENCES

**A-1. SCOPE.** This Appendix lists all forms, field manuals, technical manuals, and miscellaneous publications referenced in this manual.

**A-2. FORMS.**

Report of Discrepancy . . . . .	SF 364
Quality Deficiency Report. . . . .	SF 368
Recommended Changes to Publications and Blank Forms . . . . .	DAForm 2028/2028-2
Discrepancy in Shipment Report . . . . .	SF 361

**A-3. TECHNICAL MANUALS.**

Operator's Manual: Radioactive Test Sample, Krypton 85, Gamma MX-7338/PDR-27R . . . . .	TM 3-6665-264-10
Administrative Storage Requirements . . . . .	TM740-90-1
Destruction of Army Electronics Material . . . . .	TM 750-244-2
Hand Receipt . . . . .	TM 11-6665-230-12HR
Organizational Maintenance Repair Parts and Special Tools List for RadiacSet AN/PDR-27R (NSN 6665-00-961-0846) . . . . .	TM 11-6665-230-20P

**A-4. MISCELLANEOUS PUBLICATIONS.**

Consolidated Index of Army Publications and Blank Forms . . . . .	DAPam310-1
The Army Maintenance Management System . . . . .	DA Pam 738-750



# APPENDIX B

## MAINTENANCE ALLOCATION

### SECTION I INTRODUCTION

#### B-1. GENERAL.

This appendix provides a summary of the maintenance operations for the AN/PDR-27R. It authorizes categories of maintenance for specific equipment required to perform each function. This appendix may be used as an aid in planning maintenance operations.

#### B-2. MAINTENANCE FUNCTION.

Maintenance functions will be limited to and defined as follows:

a. INSPECT - To determine the serviceability of an item by comparing its physical, mechanical, and/or electrical characteristics with established standards through examination.

b. TEST - To verify serviceability and to detect incipient failure by measuring the mechanical or electrical characteristics of an item and comparing those characteristics with prescribed standards.

c. SERVICE - Operations required periodically to keep an item in proper operating condition, i.e., to clean (decontaminate), to preserve, to drain, to paint, or to replenish fuel, lubricants, hydraulic fluids, or compressed air supplies.

d. ADJUST - To maintain, within prescribed limits, by bringing into proper or exact position, or by setting the operating characteristics to the specified parameters.

e. ALIGN - To adjust specified variable elements of an item to bring about optimum or desired performance.

f. CALIBRATE -To determine and cause corrections to be made or to be adjusted on instruments or test measuring and diagnostic equipments used in precision measurement. Consists of comparisons of two instruments, one of which is a certified standard of known accuracy, to detect and adjust any discrepancy in the accuracy of the instrument being compared.

g. INSTALL - The act of emplacing, seating, or fixing into position an item, part, module (component or assembly) in a manner to allow the proper functioning of the equipment or system.

h. REPLACE - The act of substituting a serviceable like type part, subassembly, or module (component or assembly) for an unserviceable counterpart.

i. REPAIR - The application of maintenance services (inspect, test, service, adjust, align, calibrate, replace) or other maintenance actions (welding, grinding, riveting, straightening, facing, remachining, or resurfacing) to restore serviceability to an item by correcting specific damage, fault, malfunction, or failure in a part, subassembly, module (component or assembly), end item, or system.

j. OVERHAUL - That maintenance effort (service/action) necessary to restore an item to completely serviceable/operational condition as prescribed by maintenance standards (i.e., DMWR) in appropriate technical publications. Overhaul is normally the highest degree of maintenance performed by the Army. Overhaul does not normally return an item to like new condition.

k. REBUILD - Consists of those services/operations necessary for the restoration of unserviceable equipment to a like new condition in accordance with original manufacturing standards. Rebuild is the highest degree of materiel maintenance applied to Army equipment. The rebuild operation includes the act of returning to zero those age measurements (hours, miles, etc.) considered in classifying Army equipments/components.

#### B-3. COLUMN ENTRIES.

a. Column 1, GROUP NUMBER - Column 1 lists group numbers, the purpose of which is to identify components, assemblies, subassemblies, and modules with the next higher assembly.

b. Column 2, COMPONENT/ASSEMBLY - Column 2 contains the noun names of components, assemblies, subassemblies, and modules for which maintenance is authorized.

c. Column 3, MAINTENANCE FUNCTIONS - Column 3 lists the functions to be performed on the item listed in column 2. When items are listed without maintenance functions it is solely for purpose of having the group numbers in the MAC and RPSTL coincide.

d. Column 4, MAINTENANCE CATEGORY - Column 4 specifies, by the listing of a "work time" figure in the appropriate subcolumn(s), the lowest level of maintenance authorized to perform the function listed in column 3. This figure represents the active time required to perform that maintenance function at the indicated category of maintenance. If the number or complexity of the tasks within the listed maintenance function vary at different maintenance categories, appropriate "work time" figures will be shown for each category. The number of task-hours specified by the "work time" figure represents the average time required to restore an item (assembly, subassembly, component, module, end item or system) to a serviceable condition under typical field operating conditions. This time includes preparation time, troubleshooting time and quality assurance/quality control time in addition to the time required to perform the specific tasks identified for the maintenance functions authorized in the maintenance allocation chart. Subcolumns of column 4 are as follows:

- C - Operator/Crew
- O - Organizational
- F - Direct Support
- H - General Support
- D - Depot

e. Column 5, TOOLS AND EQUIPMENT - Column 5 specifies by code, those common tool sets (not individual tools) and special tools, test and support equipment required to perform the designated function.

f. Column 6, REMARKS - Column 6 contains an alphabetic code which leads to the remark in section IV, Remarks, which is pertinent to the item opposite the particular code.

**B-4. Tool and Test Equipment Requirements (Sect. III).**

a. TOOL OR TEST EQUIPMENT REFERENCE CODE -The numbers in this column coincide with the numbers used in the tools and equipment column of the MAC. The numbers indicate the applicable tool or test equipment for the maintenance functions.

b. MAINTENANCE CATEGORY - The codes in this column indicate the maintenance category allocated the tool or test equipment.

c. NOMENCLATURE - This column lists the noun name and nomenclature of the tools and test equipment required to perform the maintenance functions.

d. NATIONAL/NATO STOCK NUMBER - This column lists the National/NATO stock number of the specific tool or test equipment.

e. TOOL NUMBER - This column lists the manufacturer's part number of the tool followed by the Federal Supply Code for manufacturers (5-digit) in parentheses.

**B-5. REMARKS.**

a. REFERENCE CODE - This code refers to the appropriate item in section II, column 6.

b. REMARKS - This column provides the required explanatory information necessary to clarify items appearing in section II.

**SECTION II MAINTENANCE ALLOCATION CHART  
FOR  
RADIAC SET AN/PDR-27R**

(1) GROUP NUMBER	(2) COMPONENT/ASSEMBLY	(3) MAINTENANCE FUNCTION	(4) MAINTENANCE CATEGORY					(5) TOOLS & EQPT.	(6) REMARK	
			C	O	F	H	D			
00	RADIAC SET AN/PDR-27R	Inspect	0.2						2, 4 thru 7 8 4, 7 2, 7 1 thru 7 8 1 thru 7 1 thru 7	A B C D E
		Test	0.3							
		Test				1.8				
		Service	0.2							
		Replace		0.2						
		Adjust				0.5				
		Calibrate				1.0				
		Calibrate					1.5			
Repair		0.2			1.5					
Repair					1.5					
Overhaul						4.0				
01	RADIAC METER IM-203/ PDR-27R	Inspect	0.1						2, 4 thru 7 8 4, 7 2, 7 1 thru 7 8 2, 4 thru 7 1 thru 7	A B C D E
		Test	0.2							
		Test				0.5				
		Service	0.2							
		Replace		0.2						
		Adjust				0.2				
		Calibrate				1.0				
		Calibrate					1.5			
Repair		0.2			1.5					
Repair					1.5					
Overhaul						3.0				
0101	ASSEMBLY, LOW VOLTAGE	Test				0.5			4, 7	
		Adjust				0.2			4, 7	
		Replace				0.5			7	
		Repair					1.0		1 thru 7	
0102	ASSEMBLY, HIGH VOLTAGE	Test					0.5		3, 7	
		Replace					0.5		7	
		Repair					1.0		1 thru 7	
02	RADIAC DETECTOR DT-1961/PDR-27J	Inspect	0.1						7	
		Replace		0.1		0.1			2, 4 thru 7	
		Repair				1.0			2, 4 thru 7	
		Overhaul					1.5		& Depot	
03	HEADSET H-43B/U	Inspect	0.1							F F F
		Replace		0.1						
		Repair				1.5				
		Overhaul					1.5			
04	CASE, CARRYING CY- 4995/PDR-27	Inspect	0.1							
		Replace		0.1					8	
		Repair				1.5			7	
		Overhaul					2.0		Depot Facilities	

**SECTION III TOOL AND TEST EQUIPMENT REQUIREMENTS  
FOR  
RADIAC SET AN/PDR-27R**

<b>TOOL AND TEST EQUIPMENT REF.</b>	<b>MAINTENANCE CATEGORY</b>	<b>NOMENCLATURE</b>	<b>NATIONAL/NATO STOCK NUMBER</b>	<b>TOOL NO.</b>
1	D	Calibration Set, Radiac AN/UDM-1 or Calibrator Set, Radiac AN/UDM-1A	6665-00-669-0077	
2	H, D	Calibrator Set, Radiac AN/UDM-2	6665-00-179-9037	
3	D	Electro Static Voltmeter ME-147/U	6625-00-557-5672	
4	H, D	Multimeter AN/PSM-45	6625-01-139-2512	
5	H, D	Oscilloscope AN/USM-488		
6	H, D	Test Set, Transistor TS-1836/U	6625-00-893-2628	
7	H, D	Tool Kit, Electronic Equipment TK-105G	5180-00-618-8177	
8	O	Tool Kit, Electronic Equipment TK-101G	5180-00-064-5178	

**SECTION IV REMARK**

<b>REFERENCE CODE</b>	<b>REMARKS</b>
A	OPERATIONAL TEST USING TEST SAMPLE MX-7338/PDR-27R
B	CLEAN, REPLACE BATTERIES
C	GASKETS, KNOBS AND SMALL EXTERNAL HARDWARE
D	1A/R3 POTENTIOMETER
E	CALIBRATION POTENTIOMETERS
F	TM 11-5965-247-12P

## APPENDIX C

### COMPONENTS OF END ITEM AND BASIC ISSUE ITEMS LISTS

#### SECTION I INTRODUCTION

**C-1. SCOPE.** This appendix lists components of end item and basic issue items for the AN/PDR-27R to help you inventory items required for safe and efficient operation.

**C-2. GENERAL.** The Components of End Item and Basic Issue Lists are divided into the following sections:

a. **Section II. Components of End Item.** This listing is for information purposes only, and is not authority to requisition replacements. These items are part of the end item, but are removed and separately packaged for transportation or shipment. As part of the end item, these items must be with the end item whenever it is issued or transferred between property accounts. Illustrations are furnished to assist you in identifying the items.

b. **Section III. Basic Issue Items.** These are the minimum essential items required to place the AN/PDR-27R in operation, to operate it, and to perform emergency repairs. Although shipped separately, packaged BIl must be with the AN/PDR-27R during operation and whenever it is transferred between property accounts. The illustrations will assist you with hard to identify items. This manual is your authority to request/requisition replacement BIl, based on TOE/MTOE authorization of the end item.

**C-3. EXPLANATION OF COLUMNS.** The following provides an explanation of columns found in the tabular listings:

a. **Column (1) - Illustration Number (Illus. Number).** This column indicates the number of the illustration in which the item is shown.

b. **Column (2) - National Stock Number.** Indicates the National stock number assigned to the item and will be used for requisitioning purposes.

c. **Column (3) - Description.** Indicates the National Item name and, if required, a minimum description to identify and locate the item. The last line for each item indicates the FSCM (in parentheses) followed by the part number.

d. **Column (4) - Unit of Measure (U/M).** Indicates the measure used in performing the actual operational/maintenance function. This measure is expressed by a two-character alphabetical abbreviation (e.g., ea, ln, pr).

e. **Column (5) - Quantity required (Qty rqr).** Indicates the quantity of the item authorized to be used with/on the equipment,

SECTION II COMPONENTS OF END ITEM

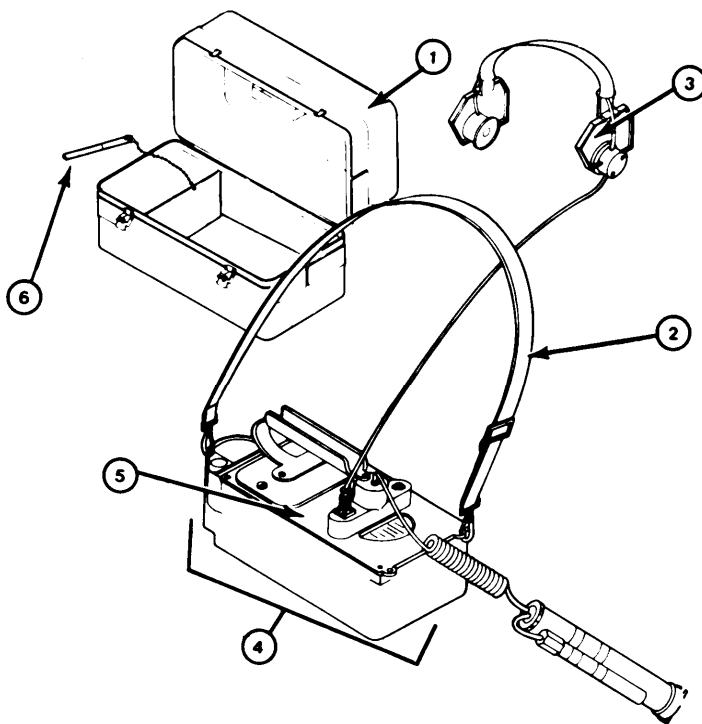

EL6NC039

(1)	(2)	(3)	(4)	(5)	
Illus. Number	National Stock Number	Description FSCM and Part Number	Usable On Code	U/M	Qty rgr.
1	6665-00-832-6157	Case, Carrying (80058) CY-4995/PDR-27R		EA	1
2	5999-00-685-9470	Harness: (80058) ST-136/PDR-27R		EA	1
3	5965-00-651-7372	Headset, Electrical: (80058) H-43B/U		EA	1
4	6665-00-961-0846	Radiac Set (80058) AN/PDR-27R		EA	1
5	6665-00-832-6158	Radiacmeter (80058) IM-203/PDR-27R		EA	1
6	6665-00-832-6159	Radioactive Test Sample (80058) MX-7338/PDR-27R)		EA	1

**SECTION III BASIC ISSUE ITEMS**

(1)	(2)	(3)	(4)	(5)
ILLUS. NUMBER	NATIONAL STOCK NUMBER	DESCRIPTION FSCM AND PART NUMBER	USABLE ON CODE	U/M QTY RQR
	5305-00-281-3118	Setscrew (97913) 320/505		EA 2
	5355-00-656-1275	Knob (15249) 521-3651527		EA 1
	6665-00-832-6167	Tray, Battery, Bottom (15249) 521-11372		EA 1
	5340-00-936-3019	Spacer, Neoprene (15249) 521-3241517		EA 2
	5330-00-222-2767	Gasket, Rubber (86579) 902-1		EA 2
	6665-00-832-6168	Battery Cover Assy, (15249) 521-11378		EA 1

The following items and their quantities are mounted in the equipment listed for storage purposes.

CASE, CARRYING C4995/PDR-27R			
National Stock Number	Description	U/M	Qty Req
5960-00-686-9101	Electron Tube (81349) 5979	EA	1
5960-00-542-6544	Electron Tube (81349) 5980	EA	1

## APPENDIX D

### ADDITIONAL AUTHORIZATION LIST

#### SECTION I INTRODUCTION

**D1. SCOPE.** This appendix lists additional items you are authorized for the support of the AN/PDR-27R.

**D-2. GENERAL.** This list identifies items that do not have to accompany the AN/PDR-27R and that do not have to be turned in with it. These items are all authorized to you by CTA, MTOE, TDA, or JTA.

**D-3. EXPLANATION OF LISTING.** National stock numbers, descriptions, and quantities are provided to help you identify and request the additional items you require to support this equipment. The items are listed in alphabetical sequence by item name under the type document (i.e., CTA, MTOE, TDA, or JTA) which authorizes the item(s) to you.

#### SECTION II ADDITIONAL AUTHORIZATION LIST

(1)	(2)		(3)	(4)
NATIONAL STOCK NUMBER	FSCM & PART NUMBER	DESCRIPTION USABLE ON CODE	U/M	QTY AUTH
6135-00-120-1020		<u>MTOE AUTHORIZED ITEMS</u> Battery, Dry BA-30.80063	ea.	12
5120-00-222-8852		Screwdriver	ea.	1
		<u>CTA AUTHORIZED ITEMS</u> (not applicable)		



## GLOSSARY

### DEFINITION OF UNUSUAL TERMS

<b>CENTIGRAY</b>	Unit of measurement of the absorbed dose of ionizing radiation. It represents the absorption of 100 ergs of nuclear (or ionizing) radiation per gram of absorbing material or tissue. This unit of measurement is used interchangeably with, and in lieu of, other units i.e., roentgen, milliroentgen, rad and millirad. For military purposes, all types of radiation will be measured in centigray (cGy).
<b>ERG</b>	The absolute centimeter-gram-second unit of energy and work. The work done when a force of one dyne is applied through a distance of one centimeter.
<b>MILLIRAD</b>	One-thousandth of a rad [(1 mrad) (.001cGY) or 10 uGy (microgray per hour)] [(1 mrad/h = 0.601 cGy/h or 10 uGy/h (microgray per hour)].
<b>MILLIROENTGENS</b>	One-thousandth of a roentgen (mR/hr) (mrad/h) (.001 cGy/h).
<b>RAD</b>	The unit of absorbed radiation dose equivalent to an energy deposition of 100 ergs/gin, i.e., a measure of the energy which the ionizing radiation imparts to matter per unit of irradiated material (1rad = 1cGy centigram).
<b>RADIOACTIVITY</b>	The spontaneous emission of radiation, generally alpha or beta radiation, often accompanied by gamma radiation from the nuclei of an unstable element.
<b>ROENTGEN</b>	The internal unit of x-radiation or gamma radiation equal to the amount of radiation that produces in one cubic centimeter of dry air at 0°C and standard atmospheric pressure ionization of either sign equal to one electrostatic unit of charge. Term is used interchangeably with Rad (see centigram).
<b>SHIELDING</b>	Is the act of reducing or preventing the passage of particles or radiation.

## APPENDIX E

### EXPENDABLE SUPPLIES AND MATERIALS LIST

#### SECTION I INTRODUCTION

**E-1. SCOPE.** This appendix lists expendable supplies and materials you will need to operate and maintain the AN/PDR-27R. These items are authorized to you by CTA 50-970, Expendable Items (Except Medical, Class V, Repair Parts, and Heraldic Items).

**E-2. EXPLANATION OF COLUMNS.**

**a. Column 1 - Item number.** This number is assigned to the entry in the listing and is referenced in the narrative instruction to identify the material (e.g., "Use cleaning compound, item 5, App. D").

**b. Column 2 - Level.** This column identifies the lowest level of maintenance that requires the listed item.

- C - Operator/Crew
- O - Organizational Maintenance

**c. Column 3 | National Stock Number.** This is the National Stock number assigned to the item; use it to request or requisition the item.

**d. Column 4 | Description.** Indicates the Federal Item name and, if required, a description to identify the item. The last line for each item indicates the Federal Supply Code for Manufacturer (FSCM) in parentheses followed by the part number.

**e. Column 5 | Unit of Measure (U/M).** Indicates the measure used in performing the actual maintenance function. This measure is expressed by a two-character alphabetical abbreviation (e.g., ea, in, pr). If the unit of measure differs from the unit of issue, requisition the lowest unit of issue that will satisfy your requirements.

#### SECTION II EXPENDABLE SUPPLIES AND MATERIALS LIST

(1)	(2)	(3)	(4)	(5)
ITEM NUMBER	LEVEL	NATIONAL STOCK NUMBER	DESCRIPTION	U/M
1	C	6135-00-120 1020	Battery, Dry BA-30: (80063)	EA
2	O	8040-00-390 7959	Adhesive, EC 847	QT
3	O	8010-00-865-2054	Enamel, Gray (81349)	QT

**ALPHABETICAL INDEX**

<b>Subject</b>	<b>Page</b>	<b>Paragraph</b>
<b>A</b>		
Additional Authorization List . . . . .	D-1	
Administrative Storage . . . . .	A-5	1-5
Appendix-A References . . . . .	A-1	
Appendix-B Maintenance Allocation . . . . .	B-1	
Appendix-C Components of End Item and Basic issue items Lists . . . . .	c-1	
<b>B</b>		
Components of End Item List . . . . .	C-1	
Consolidated Index of Army Publications and Blank Forms . . . . .	1-1	1-2
<b>D</b>		
Description and Use of Operators Controls . . . . .	2-1	2-1
Destruction of Army Electronics Material . . . . .	1-1	1-4
Difference in Models. . . . .	1-6	1-11
<b>E</b>		
Equipment Data . . . . .	1-6	1-12
Equipment Description and Data . . . . .	1-2	
Equipment Purpose, Capabilities, and Features . . . . .	1-2	1-9
Expendable Supplies and Materials List . . . . .	E-1	
<b>G</b>		
General Information. . . . .	1-1	
Glossary . . . . .	G-1	
<b>H</b>		
Hand Receipt . . . . .	1-1	1-7
<b>L</b>		
Location and Description of Major Components . . . . .	1-2	1-10
Lubrication . . . . .	3-1	3-1
<b>M</b>		
Maintenance Forms, Records, and Reports . . . . .	1-1	1-3
Maintenance Procedures, Operator . . . . .	3-1	3-3
Maintenance Procedures, Organizational . . . . .	4-13	4-6

**ALPHABETICAL INDEX (continued)**

<b>Subject</b>	<b>Page</b>	<b>Paragraph</b>
<b>N</b>		
Nomenclature .....	1-2	1-8
<b>O</b>		
Operation Under Usual Condition .....	2-16	
Operator Controls and Indicators .....	2-1	2-1
Operating Instructions .....	2-16	2-5
Operator Maintenance Instructions .....	3-1	3-3
Organizational Maintenance Instructions .....		
<b>P</b>		
PMCS Procedures .....	2-1	2-3
Preparation for Storage and Shipment .....	4-13	4-7
Preventive Maintenance Check and Services .....	4-2	4-3
Principles of Operation .....	1-7	1-14
<b>R</b>		
References .....	A-1	
Repair and Replacement of Parts .....	4-13	4-5
Reporting Equipment Improvement Recommendations (EAR) .....	1-1	1-6
Routine Checks .....	2-2	2-4
<b>S</b>		
Safety, Care and Handling .....	1-7	1-13
Scope .....	1-1	1-1
Service Upon Receipt .....	4-1	4-2
<b>T</b>		
Tools, Repair Parts and Special Tools .....	4-1	4-1
Troubleshooting Procedures .....	3-1	3-2

By Order of the Secretary of the Army:

**JOHN A. WICKHAM JR.**  
*General, United States Army*  
*Chief of Staff*

Official:

**ROBERT M. JOYCE**  
*Major General, United States Army*  
*The Adjutant General*

DISTRIBUTION:

To be distributed in accordance with DA Form 12-50 requirements  
for AN/PDR-27R.

☆ U.S. GOVERNMENT PRINTING OFFICE : 1990 0 - 261-872 (21208)

RECOMMENDED CHANGES TO EQUIPMENT TECHNICAL PUBLICATIONS



THEN... JOT DOWN THE DOPE ABOUT IT ON THIS FORM. CAREFULLY TEAR IT OUT, FOLD IT AND DROP IT IN THE MAIL!

SOMETHING WRONG WITH THIS PUBLICATION?

FROM: (PRINT YOUR UNIT'S COMPLETE ADDRESS)  
 Commander  
 Stateside Army Depot  
 ATTN: AMSTA-US  
 Stateside, N.J. 07703-5007

DATE SENT 10 July 1975

PUBLICATION NUMBER  
 TM 11-5840-340-12

PUBLICATION DATE  
 23 Jan 74

PUBLICATION TITLE  
 Radar Set AN/PRC-76

BE EXACT... PIN-POINT WHERE IT IS

PAGE NO	PARA-GRAPH	FIGURE NO	TABLE NO
2-25	2-28		
3-10	3-3		3-1
5-6	5-8		

IN THIS SPACE TELL WHAT IS WRONG AND WHAT SHOULD BE DONE ABOUT IT:

Recommend that the installation antenna alignment procedure be changed throughout to specify a 2° IFF antenna lag rather than 1°.

REASON: Experience has shown that with only a 1° lag, the antenna servo system is too sensitive to wind gusting in excess of 25 knots, and has a tendency to rapidly accelerate and decelerate as it hunts, causing strain to the drive train. Hunting is minimized by adjusting the lag to 2° without degradation of operation.

Item 5, Function column. Change "2 db" to "3db."

REASON: The adjustment procedure for the TRANS POWER FAULT indicator calls for a 3 db (500 watts) adjustment to light the TRANS POWER FAULT indicator.

Add new step f.1 to read, "Replace cover plate removed in step e.1, above."

REASON: To replace the cover plate.

Zone C 3. On J1-2, change "+24 VDC to "+5 VDC."

REASON: This is the output line of the 5 VDC power supply. +24 VDC is the input voltage.

TEAR ALONG PERFORATED LINE

PRINTED NAME, GRADE OR TITLE, AND TELEPHONE NUMBER  
 SSG I. M. DeSpirito 999-1776

SIGN HERE

DA FORM 2028-2  
 1 JUL 79

PREVIOUS EDITIONS ARE OBSOLETE.

PS--IF YOUR OUTFIT WANTS TO KNOW ABOUT YOUR RECOMMENDATION MAKE A CARBON COPY OF THIS AND GIVE IT TO YOUR HEADQUARTERS

RECOMMENDED CHANGES TO EQUIPMENT TECHNICAL PUBLICATIONS



THEN...JOT DOWN THE DOPE ABOUT IT ON THIS FORM. CAREFULLY TEAR IT OUT, FOLD IT AND DROP IT IN THE MAIL.

**SOMETHING WRONG WITH THIS PUBLICATION?**

FROM: (PRINT YOUR UNIT'S COMPLETE ADDRESS)

DATE SENT

PUBLICATION NUMBER

TM 11-6665-230-12

PUBLICATION DATE

3 Sep 1984

PUBLICATION TITLE

Radiac Set AN/PDR-27R

BE EXACT PIN-POINT WHERE IT IS

PAGE NO.

PARA-GRAPH

FIGURE NO.

TABLE NO.

IN THIS SPACE TELL WHAT IS WRONG AND WHAT SHOULD BE DONE ABOUT IT:

TEAR ALONG PERFORATED LINE

PRINTED NAME GRADE OR TITLE AND TELEPHONE NUMBER

SIGN HERE

DA FORM 2028-2  
1 JUL 79

PREVIOUS EDITIONS ARE OBSOLETE

P.S.--IF YOUR OUTFIT WANTS TO KNOW ABOUT YOUR RECOMMENDATION MAKE A CARBON COPE OF THIS AND GIVE IT TO YOUR HEADQUARTERS.

FILL IN YOUR  
UNIT'S ADDRESS

FOLD BACK

DEPARTMENT OF THE ARMY

\_\_\_\_\_  
\_\_\_\_\_

OFFICIAL BUSINESS

Commander  
US Army Communications-Electronics Command  
and Fort Monmouth  
ATTN: DRSEL-ME-MP  
Fort Monmouth, New Jersey 07703-5007

TEAR ALONG PERFORATED LINE



# THE METRIC SYSTEM AND EQUIVALENTS

## WEIGHT MEASURE

1 Centimeter = 10 Millimeters = 0.01 Meters = 0.3937 Inches  
 1 Meter = 100 Centimeters = 1000 Millimeters = 39.37 Inches  
 1 Kilometer = 1000 Meters = 0.621 Miles

## WEIGHTS

1 Gram = 0.001 Kilograms = 1000 Milligrams = 0.035 Ounces  
 1 Kilogram = 1000 Grams = 2.2 lb.  
 1 Metric Ton = 1000 Kilograms = 1 Megagram = 1.1 Short Tons

## LIQUID MEASURE

1 Milliliter = 0.001 Liters = 0.0338 Fluid Ounces  
 1 Liter = 1000 Milliliters = 33.82 Fluid Ounces

## SQUARE MEASURE

1 Sq. Centimeter = 100 Sq. Millimeters = 0.155 Sq. Inches  
 1 Sq. Meter = 10,000 Sq. Centimeters = 10.76 Sq. Feet  
 1 Sq. Kilometer = 1,000,000 Sq. Meters = 0.386 Sq. Miles

## CUBIC MEASURE

1 Cu. Centimeter = 1000 Cu. Millimeters = 0.06 Cu. Inches  
 1 Cu. Meter = 1,000,000 Cu. Centimeters = 35.31 Cu. Feet

## TEMPERATURE

$5/9(^{\circ}\text{F} - 32) = ^{\circ}\text{C}$   
 212° Fahrenheit is equivalent to 100° Celsius  
 90° Fahrenheit is equivalent to 32.2° Celsius  
 32° Fahrenheit is equivalent to 0° Celsius  
 $9/5^{\circ}\text{C} + 32 = ^{\circ}\text{F}$

## APPROXIMATE CONVERSION FACTORS

TO CHANGE	TO	MULTIPLY BY
Inches	Centimeters	2.540
Feet	Meters	0.305
Yards	Meters	0.914
Miles	Kilometers	1.609
Square Inches	Square Centimeters	6.451
Square Feet	Square Meters	0.093
Square Yards	Square Meters	0.836
Square Miles	Square Kilometers	2.590
Acres	Square Hectometers	0.405
Cubic Feet	Cubic Meters	0.028
Cubic Yards	Cubic Meters	0.765
Fluid Ounces	Milliliters	29.573
its	Liters	0.473
arts	Liters	0.946
allons	Liters	3.785
Ounces	Grams	28.349
Pounds	Kilograms	0.454
Short Tons	Metric Tons	0.907
Pound-Feet	Newton-Meters	1.356
Pounds per Square Inch	Kilopascals	6.895
Miles per Gallon	Kilometers per Liter	0.425
Miles per Hour	Kilometers per Hour	1.609

TO CHANGE	TO	MULTIPLY BY
Centimeters	Inches	0.394
Meters	Feet	3.280
Meters	Yards	1.094
Kilometers	Miles	0.621
Square Centimeters	Square Inches	0.155
Square Meters	Square Feet	10.764
Square Meters	Square Yards	1.196
Square Kilometers	Square Miles	0.386
Square Hectometers	Acres	2.471
Cubic Meters	Cubic Feet	35.315
Cubic Meters	Cubic Yards	1.308
Milliliters	Fluid Ounces	0.034
Liters	Pints	2.113
Liters	Quarts	1.057
ers	Gallons	0.264
ms	Ounces	0.035
ograms	Pounds	2.205
Metric Tons	Short Tons	1.102
Newton-Meters	Pounds-Feet	0.738
Kilopascals	Pounds per Square Inch	0.145
ometers per Liter	Miles per Gallon	2.354
ometers per Hour	Miles per Hour	0.621



**PIN: 056902-000**